

Connections for Architectural Precast Concrete

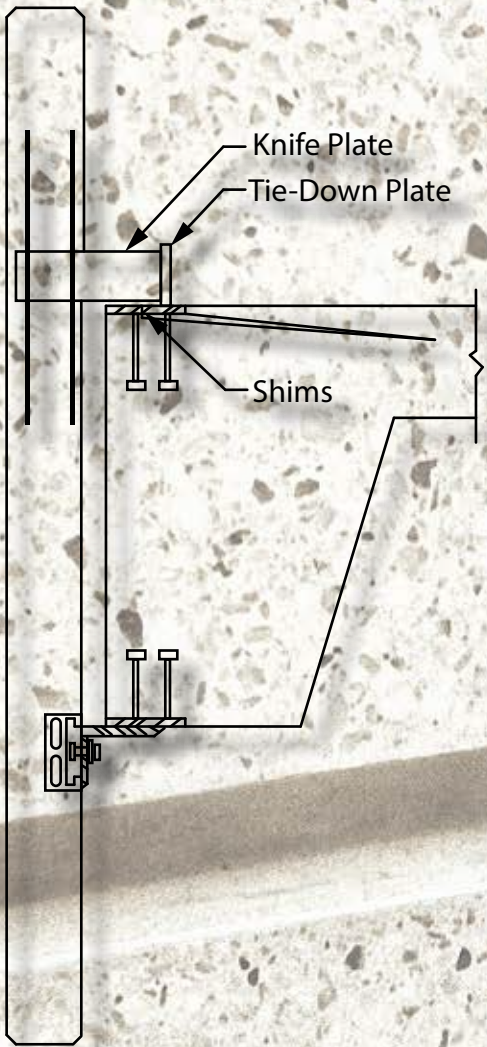

CONNECTIONS FOR ARCHITECTURAL PRECAST CONCRETE

Connections are a significant design consideration that influences safety, performance, and economy of architectural precast concrete enclosure systems. Many different connection details may be required to accommodate the multitude of sizes and shapes of precast concrete units and varying support conditions.

The purpose of this article is to provide connection design concepts and other considerations to Architects. While connection design is normally delegated to the precast concrete supplier, design criteria and load paths must be specified by the Structural Engineer of Record (SER) and the Architect must be aware of the impact of connections on final detailing.

Whether an architectural precast concrete element is used in a loadbearing or a non-loadbearing application, various forces must be considered in connection design. In non-loadbearing applications, a cladding panel must resist its self weight and all other appropriate forces and loads, such as seismic, wind, snow, restraint of volume changes and effects of support system movement, construction loads, loads from adjacent materials, and any other specified loads. These loads and forces are transferred by the architectural precast concrete element through connections to supporting structure. If a panel is loadbearing, then in addition to the above, some connections must also resist and transfer dead and live loads imposed on it by floor and roof elements.

A major advantage of precast concrete construction is rapid installation. To fully realize this benefit and to maximize economy, field connections should be simple, repetitious, and easy to install. Precast concrete suppliers and erectors have developed preferred connections over the years that suit particular production and/or installation techniques.

Connections should comply with local building codes and satisfy functional and aesthetic requirements, such as recessing for flush floors and/or exposed ceilings. General concepts governing the design, performance, and material requirements of connections can be formulated. For the most effective design, along with efficient connection details, it is recommended that the designer coordinate connection concepts with a precast concrete manufacturer prior to finalizing the plans.

Terminology: The following describes terms common to the precast concrete industry. A precast concrete unit is used to generically represent a wall panel, window panel, spandrel, or column cover that is attached to the main building **structure**. A **connection** is the element that is used to make the attachment of the unit to the structure and will consist of parts embedded in concrete and parts that are field installed, each of which may be called a **connector**. The **body** is the main part of the connection that bridges between a unit and the structure. **Fasteners** are connectors such as bolts or welds used to attach the body to other portions of the connection. The **seat** or **haunch** is the projecting body of a connection from a precast concrete unit upon which the weight of the unit is supported. A **bracket** or **outrigger** is a concrete or steel element

projecting from a column or edge beam that supports the seat or haunch from a precast concrete unit and transfers load to the structure. **Shear plates** are field welded connectors that primarily transfer in-plane or out-of-plane horizontal forces to the structure. **Tiebacks** are connections that resist out-of-plane forces due to wind, seismic, and the effect of eccentricity between vertical load and the point of support. **Anchors** are parts of a connection that are embedded in concrete, either in the precast concrete unit or main structure, to transmit forces into the concrete. Anchors typically are headed studs, bolts, or deformed bar anchors. **Post-installed anchors** include expansion or adhesive anchors. **Embedments** are items, usually steel fabrications with anchors, cast into concrete. **Inserts** are usually proprietary items cast into concrete provided in many configurations to serve many different functions. **Adjustable inserts** are proprietary assemblies that have internal adjustability.

Design Coordination

A successful project requires close cooperation and coordination between all participants. With current construction complexity, it is essential to have design input by the precast concrete supplier at an early stage. The supplier will be able to provide suggestions and designs that optimize panel size and joint locations for economy and efficiency.

In the most common contractual arrangement, final structural design of the precast concrete units and final design and detailing of connections of the units to the structure are performed by a Specialty Structural Engineer (SSE) either working for or contracted with the precast concrete supplier. It is imperative that design responsibility be clearly defined in the contract documents.

If the SSE is specified as responsible for the final precast concrete design, the applicable code, design loads, and performance criteria must be specified by the SER in the construction documents. For best coordination, the SER should describe intended load paths. This is best communicated by showing conceptual connections and connection points in the construction documents. For steel frame structures, the SER should determine how far in advance the final connections of the frame and/or floor slabs must be completed prior to precast concrete panel erection. For cast-in-place concrete structures, the SER should determine minimum concrete strength necessary prior to erecting precast concrete units.

The SER will have responsibility to design the supporting and bracing structure to adequately resist the connection forces generated in the precast concrete system. This should include both strength and stiffness. The strength requirement is obvious. In the erection of the precast concrete units, it is assumed that the units can be aligned in accordance with specified erection tolerances when the units are first set. Hence, adequate stiffness is defined by structure deformations that allow erection within tolerance. The best example is multiple panels supported by a beam in a single bay. Sufficient stiffness should be provided so the first panel set does not have to be realigned as subsequent panels are set.

Gravity supports for precast concrete panels ideally transmit vertical load directly to the building columns. However, it is common to locate gravity connections adjacent to columns due to geometric or detailing constraints. In this case, vertical load will be applied to the floor or roof deck structure. Two details are possible. If the grav-

ity connections can be concealed in the interior finish, load will be applied to the edge of the floor slab or roof deck. This generally means that the deck must cantilever some distance over the edge beam. In the precast connection design, it is assumed that the deck cantilever has the strength and stiffness necessary to carry the vertical load and allow panel installation within specified erection tolerances. If the finish will not conceal the gravity connection, a penetration in the edge of the deck will be required and a bracket will have to be provided from the side of the edge beam to accept the gravity load. In this case, eccentric load will be applied to the edge beam and it is assumed that sufficient strength and both flexural and torsional stiffness is provided in the edge beam to carry the vertical load and allow panel installation within the specified erection tolerance. Supplemental framing may be required to accomplish this. The SSE will not evaluate the supporting structure to determine the need for such supplemental framing. This supplemental framing should be supplied and installed with the supporting structure so it is in place at the time of the precast concrete installation. It is generally not feasible to extend gravity connections to the centerline of the edge beam since interior finishes will not cover such a detail.

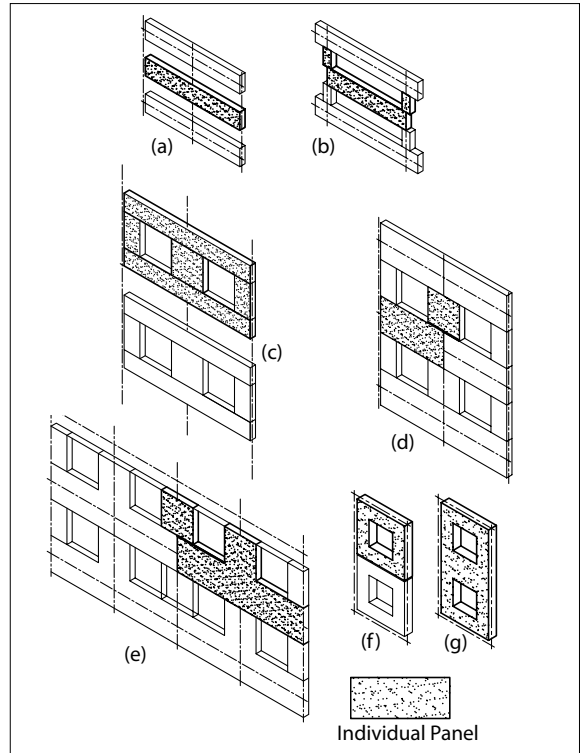

Figure 1 Typical arrangement of precast concrete panels.

Another important role of the SER is to review the precast concrete erection drawings and design work for compatibility with the original intent of the structural design. This is the final opportunity to verify that the SSE has properly interpreted the intent of the construction documents.

Connection Fundamentals

The first step in developing an architectural precast concrete project is establishing panel jointing to use economical panel sizes and coordinate with the floor and column locations in the structure. The second step is to develop the concepts of the connection system so the load points on the structure are coordinated and directions of connection rigidity versus directions of connection flexibility can be set. Beyond these two steps, the work is in the design and detailing.

Figure 1 shows a few of the many possible panel configurations for a wall. Figure 2 illustrates some common connection arrangements for different panel types. Figure 2(a) represents a typical floor-to-floor wall unit. Figures 2(b) and (c) show possible connection locations for a narrow unit, such as a column cover, and Fig. 2(d) shows a wide unit, such as a spandrel. As shown in Fig. 2, panel connections generally consist of two bearing connections and a

minimum of four tieback connections. Bearing connections and tieback connections are sometimes combined. Figure 2(d) also shows optional intermediate tieback connections. The primary purpose of intermediate tiebacks is to control concrete tensile stresses due to out-of-plane bending of a panel. These connections may also be used to resist in-plane seismic forces because the connections can be rigid in the direction parallel to the length of the panel without restraining panel shortening due to temperature or shrinkage.

The connection system should not include more than two bearing connections for each panel. Precast concrete panels are very rigid and will not allow a reliable distribution of gravity loads to more than two bearing points. The bearing connections for a given panel should also be located at the same elevation so deflections of supporting frame members do not cause distribution of gravity load different than planned.

A panel may be subjected to gravity loads, lateral loads normal to the plane of the panel, and lateral loads in the plane of the panel. For vertical load and out-of-plane load, Fig. 3 illustrates how forces are resolved in gravity and tieback connections to resist the effects of the loads. Note that the tieback connections get components of force directly from the out-of-plane loads plus stabilize the panel when the vertical load is eccentric from the point of vertical support.

As will be discussed in more detail later in the article, panels and structural systems will move due to time dependent changes in the materials, environmental effects, or loads. While connections must have strength and stiffness in the directions that forces are applied, common connection detailing will allow movements in other directions to avoid generating large forces if those movements were restrained. Allowance for movement in connections requires consideration of in-plane movements both horizontally and vertically. Generally, movements out-of-plane are not considered because forces will have to be resisted in the out-of-plane direction. Movement can be allowed by sliding, for example bearings sliding on shim stacks or bolts sliding in slotted holes, or by flexing where a ductile steel element is allowed to bend.

A series of typical connection details with an explanation of the connection function are presented at the end of this article.

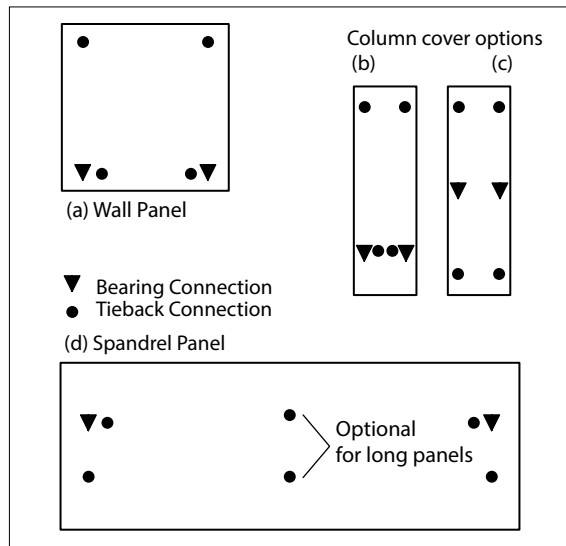

Figure 2 Typical cladding panel connector locations.

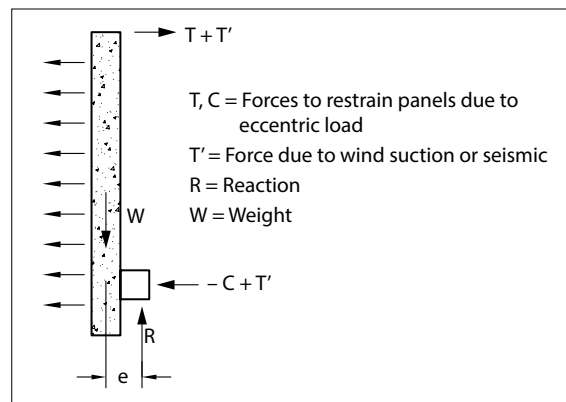

Figure 3 Forces on a panel subjected to wind suction or seismic and eccentric loading.

Connection Hardware and Materials

Hardware in connections will generally consist of an embedment in the precast concrete unit, an embedment in the supporting structure, a connector element to bridge between the precast concrete unit and the supporting structure, and fastening devices. Anchors into concrete usually consist of reinforcing bars, deformed bar anchors, and headed stud anchors. These anchors are welded to steel shapes such as plates, angles, channels, hollow structural sections, or fabricated steel assemblies to make up an embedment to be cast into concrete. Embedments into the concrete might also include proprietary threaded or weldable inserts.

The connector elements that bridge between the precast concrete unit and the supporting structure are usually flat plates, angles, special steel fabrications, or threaded rods. In welded connections, these elements may be plain pieces. In bolted connections, slotted or oversize holes are generally provided to accommodate field tolerances or provide sliding elements to accommodate movements.

Fastening devices in connections primarily consist of welds or bolts. However, post-installed anchors or grout are occasionally used. Shims are not considered fasteners, but do serve as load transfer devices.

Welded connections are structurally efficient and easily adapted to varying field conditions.. Welded connections can be completed only after final alignment.

Hoisting and setting time is critical for economical erection. Welding that must be executed prior to the release of the unit from hoisting equipment should be minimized.

Welding should be performed in accordance with the erection drawings by personnel that have been certified for the welding procedures specified. The type, size, length and location of welds, and any critical sequences should be clearly defined on the erection drawings. All welding, including tack welds, should be made in accordance with the applicable provisions of the American Welding Society (AWS).

Welding on galvanized hardware requires proper procedures to avoid contamination of the weld metal. Cold galvanizing or zinc-rich paint should be applied over welded areas to replace removed galvanizing.

When welding is performed on embedments in concrete, thermal expansion and distortion of the steel may induce cracking or spalling in the surrounding concrete. The extent of cracking and distortion of the metal is dependent on the amount of heat generated during welding and the stiffness of the steel element. Using thicker steel sections can minimize distortion. A minimum of 1/4 in. (6 mm) is recommended for plates. Heat may be reduced by:

1. Use of low-heat welding rods of small diameter.
2. Use of intermittent, rather than continuous, welds.
3. Use of smaller welds and multiple passes.

Some designers specify use of stainless steel connections in highly corrosive environments to prevent long-

term corrosion. Welding of stainless steel produces more heat than conventional welding. The increased heat input, plus a higher coefficient of thermal expansion, will create greater cracking potential in the concrete adjacent to embedments. A good detailing solution is to keep embedment edges isolated from adjacent concrete to allow expansion during welding without spalling the concrete. Sealants, sealing foams, clay, or other materials placed around plate edges prior to casting concrete can be used to create this isolation.

Bolted connections often simplify and speed up erection operations because the connections can resist force immediately upon bolt installation allowing a crane to be released more quickly. When considered in the connection detailing, final alignment and adjustment of the panel can be made at a later time.

Standard bolt sizes used in the industry are 3/4, 1, or 1 1/4 in. (19, 25, or 32 mm) diameter. High strength bolts are not commonly used. Coil thread stock or coil bolts, which have a coarse thread, are also used. The coarse thread allows quicker installation and is less prone to damage.

Bolted connections must allow for construction tolerances. Slotted or oversized holes accommodate variation and tolerance. (Fig. 4). When slotted holes are also intended to allow structure movements by bolt sliding, the slots must be long enough to account for tolerances plus the amount of planned movement. Plate washers with off-center holes allow maximum flexibility without requiring separate size parts (Fig. 4[c]). For sliding connections, the bolts should be snug, but not so tight to restrict movement within a slot. Low friction washers (Teflon or nylon) may be used to improve movement capability. Roughness at sheared or flame-cut edges should be removed. Bolts should be properly secured, with lock washers, liquid thread locker, or other means to prevent tightening or loosening.

Post-installed anchors, including expansion anchors and adhesive anchors, are often used as connections at foundations or for corrective measures when cast-in inserts are mislocated or omitted. Design provisions are provided in ACI 318, *Building Code Requirements for Structural Concrete*, and may be used if post-installed anchors are qualified in accordance with ACI 355.2 or ACI 355.4. Installation must be in strict conformance with the manufacturer's printed installation instructions.

Expansion anchors are inserted into drilled holes in hardened concrete. Performance of these anchors is dependent on the quality of field workmanship. Strength is obtained by tightening the bolt or nut, thus

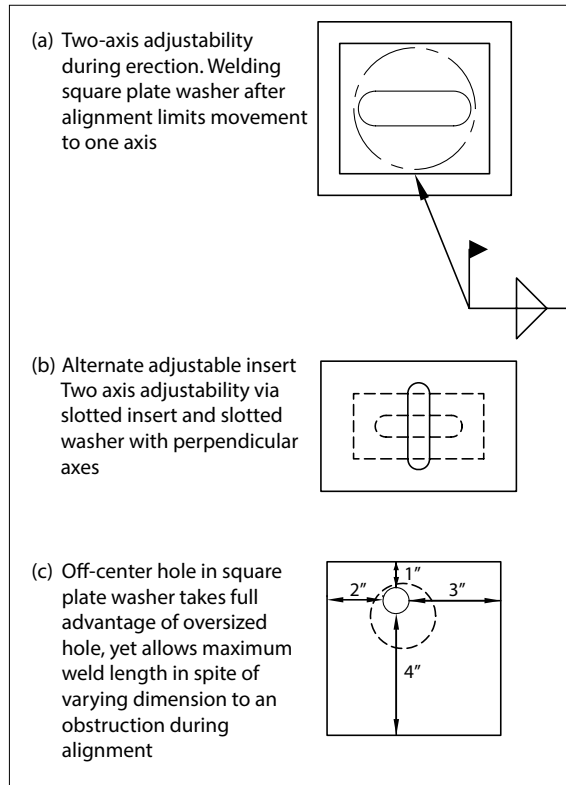

Figure 4 Slotted or oversized holes.

expanding parts of the anchor, which exert lateral pressure on the concrete. Performance of expansion anchors when subjected to stress reversals, vibrations, or earthquake loading is such that the designer should carefully consider their use for these load conditions.

Adhesive anchors depend on bond of the adhesive to the anchor and bond of the adhesive to the concrete for force transfer. The adhesive may exhibit reduced bond strength at temperatures in the 140 to 150°F (60 to 66°C) range. Such temperatures may be experienced in warm climates, particularly in façade panels with dark aggregates. Similarly, adhesive anchors may not be allowed in fire-rated connection assemblies.

Grouting or drypacking of connections is not widely used, apart from base plates or loadbearing units. The difficulty in maintaining exact elevations and the inability to allow movements and still maintain weather tightness must also be considered. Grouting should be used carefully when installed during temperatures below or near freezing. Units with joints that are to be drypacked are usually supported with shims or leveling bolts until drypack has achieved adequate strength. Shims used for this purpose should be subsequently removed to prevent them from permanently carrying the load or to facilitate joint sealant installation. A dry-packed joint requires a joint wider than 1 in. (25 mm) for best results.

Grouted dowel/anchor bolt connections depend on their diameter, embedded length, and bond developed. Placement of grout during erection usually slows down the erection process. Any necessary adjustment or movement that is made after initial set of the grout may destroy bond and reduce strength. It may be better to provide supplemental bolted connections to expedite erection.

Erection drawings should show the required grout strength:

1. Before erection can continue.
2. Before bracing can be removed.
3. At 28 days.

Corrosion Protection of Connections

The need for corrosion protection will depend on the actual conditions connections will be exposed to in service. Connection hardware generally needs protection if exposed to weather or a corrosive environment.

Protection may be provided by:

1. Paint with shop primer.
2. Coating with zinc-rich paint (98% pure zinc in dried film).
3. Chromate plating.
4. Zinc metallizing or plating.
5. Hot dip galvanizing.

6. Epoxy coating.
7. Stainless steel.

The cost of protection increases in the order of listing. Proper cleaning of hardware prior to protective treatment is important. It should be noted that threaded parts of bolts, nuts, or plates should be electroplated, not epoxy coated or galvanized, unless they are subsequently rethreaded prior to use or threads are oversized.

Where connections requiring protection are not readily accessible for the application of zinc-rich paint or metallizing after erection, they should be metallized or galvanized prior to erection and the connections bolted, where possible. If welding is required as part of the field assembly, the weld slag must be removed and the weld painted or otherwise repaired to match the parent material. For galvanized items, the galvanizing repair paint should be a minimum of 0.004 in. (0.10 mm) thick, conform to ASTM A780, and be applied in conformance with the manufacturer's recommendations.

Special care should be taken when galvanized assemblies are used. Many parts of connection components are fabricated using cold-rolled steel or cold working techniques, such as bending of anchor bars. Any form of cold working reduces the ductility of steel. Operations such as punching holes, notching, shearing, and sharp bending may lead to strain-age embrittlement of susceptible steels. This is particularly the case with high-carbon-content steel. The embrittlement may not be evident until after the work has been galvanized. This occurs because aging is relatively slow at ambient temperatures but is more rapid at the elevated temperature of the galvanizing bath.

The recommendations of the American Hot Dip Galvanizers Association and the practices given in ASTM A143, *Recommended Practice for Safeguarding Against Embrittlement of Hot Dip Galvanized Structural Steel Products* and Procedure for Detecting Embrittlement, and CSA Specification G164, *Galvanizing of Irregularly Shaped Articles*, should be followed.

Fire Protection of Connections

Fireproofing of connections may be necessary, depending on building codes and/or insurance requirements.

Connections that can be weakened by fire, and thereby jeopardize the structure's stability, should be protected to the same degree as required for the member being connected. For example, when an exposed steel bracket supports a precast concrete element that is required to have a designated fire rating, the steel bracket must be protected to the same fire rating. Fireproofing of connections is usually accomplished with sprayed cementitious or mineral fiber fireproofing, intumescent mastic compounds, or enclosure with gypsum wallboard.

Many connections simply provide stability and are under little or no stress in service. While fire could substantially reduce the strength of such connections, fire protection is not necessary. Connections that have steel elements encased in concrete, drypacking, or grout after erection usually need no additional protection.

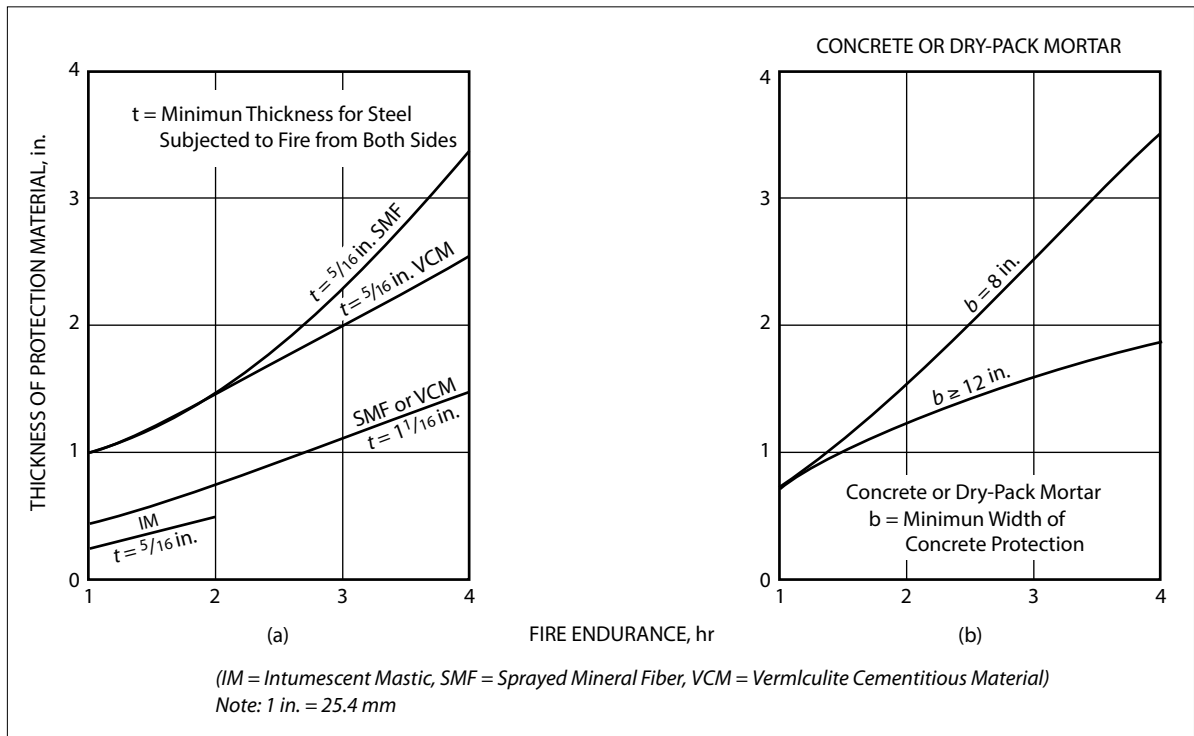

Figure 5 Thickness of fire protection materials on steel connection components.

Figure 5(a) shows the thicknesses of various, commonly used, fire-protection materials required for fire endurances up to 4 hours when applied to connections comprised of structural steel shapes. Values shown are based on a critical steel temperature of 1000°F (538°C) where strength is reduced to about 65% of that at normal temperature. The values in Fig. 5(b) are applicable to concrete or drypack mortar encasement of structural steel shapes used as brackets.

When a rational analysis or design for fireproofing is not performed and concrete is used to fireproof connections in the field, a conservative estimate would suggest that such concrete should have a thickness in inches corresponding to specified hours of fire rating. Unless the nature of the detail itself supports such concrete, it should be reinforced with a light wire fabric.

Design Considerations

The primary purpose of a connection is to transfer loads applied to a panel to the supporting structure. Depending on the type of load and the function of the structure, there may also be performance objectives to be achieved that must be considered in the design and detailing of connections. As applicable, connections must satisfy criteria including:

1. **Strength.** A connection must have the strength to safely transfer forces to which it will be subjected. Forces may be generated from the following:
 - a. Gravity load
 - b. Wind, seismic, and blast loads.
 - c. Forces from restraint of material volume change.
 - d. Forces induced by restrained differential movements between a panel and the supporting structure.
 - e. Forces required for stability and equilibrium.
 - f. Loads from adjacent materials, such as windows, louvers, signs, and other panels.
2. **Ductility.** This is the ability of a connection to accommodate large, inelastic deformations without failure. If required, ductility is generally achieved by designing connections so steel components yield prior to failure of concrete.
3. **Volume change accommodation.** Creep, shrinkage, or temperature strains can induce large stresses into precast concrete components and their supports if connections are detailed to restrain such deformations. The most common approach to connection detailing is to allow movements to occur through sliding or steel deformation to minimize or eliminate restraint.
4. **Durability.** When exposed to weather or used in a corrosive atmosphere, connections should be adequately protected with concrete, paint, galvanizing, or other coatings. Architectural precast is rarely subjected to severe environments. However, one notable exception is cladding on parking structures where durability is a consideration.
5. **Fire resistance.** Connections should be protected to the same fire resistance as the member that is being connected. If required, connection materials can be protected using concrete encasement, intumescent mastic, sprayed mineral fiber, or vermiculite cementitious material.
6. **Constructability and economy.** The following list reflects some of the items that should be considered when designing and detailing connections:
 - a. Use standard connection types.
 - b. Use standard hardware items and as few different sizes as possible.
 - c. Avoid reinforcement and hardware congestion.
 - d. Avoid penetration of forms.
 - e. Use appropriate clearances.
 - f. Use industry production and erection tolerances.

- g. Minimize time for suspending units from hoist or crane.
- h. Provide for appropriate field adjustment.
- i. Provide accessibility to complete the connection from the same floor level.
- j. Minimize length and size of field welds.

Wind considerations

Building codes and standards define procedures to determine wind loads on buildings. Wind tunnel tests may be required for buildings of irregular shape or where the location of the structure results in channeling effects. Data from such tests must be supplied to the SSE performing the precast concrete design.

Seismic considerations

Seismic forces are generated in a structure as inertial forces due to accelerations from ground motions during an earthquake. Building codes and standards define the procedures for determination of forces and structure deformations. The two primary effects on connections are forces for strength design and accommodation of building drift in detailing. If exterior wall units are not part of the lateral force-resisting system of the structure, drift of the structure must be allowed to occur without transfer of forces through the connections to the exterior panel system. Interstory drift, which is the difference in horizontal lateral displacement between two floors, may be between 1 and 2% of story height. Cladding connections may have to accommodate several inches of movement between floors.

Blast resistance

Blast resistance may be specified for many industrial facilities that may be subject to a possible accidental explosion or buildings judged to be a potential target for attack. Blast loading is characterized by very high loads acting over very short periods of time—typically measured in milliseconds. Ductile materials and redundant systems can be used to dissipate energy from a blast.

Precast concrete cladding wall panel connection details may be strengthened versions of conventional connections with a likely significant increase in connection hardware. In most cases, required connection capacities are higher than those required for conventional loads. For a detailed discussion of blast effects, see DN 14, “Blast Considerations”.

Cladding/Structure Interaction

The following discussion applies to architectural precast concrete units used only as cladding. Connections must resist forces and allow movement. Movements due to time dependent material changes and environmental effects have been previously discussed. This section will focus on movements due to lateral loads. A

structure will sway when subjected to lateral loads. As it does, there will be differential drift between floors. The panel arrangement and locations of joints combined with the directions that the connection system allows movements will influence the size of joints, selection of sealant materials, and interfacing with other façade elements, in addition to the design and detailing of the connections. The fundamental objective is to design a system with compatible behavior of connections, joints, sealants, and other façade elements.

Connection detailing will determine the response of a panel to sway of a structure. Figure 6 is presented to illustrate the different ways panels may move that must be considered for developing a system with compatibility of elements.

In-Plane Translation shown in Fig. 7(a) occurs when the panel is fixed in-plane to one level. The panel translates laterally with that level, remaining vertical in elevation. Spandrel panels and wall panels with height less than width are typically designed to behave this way. When panels are designed to translate, the horizontal joint at each level should remain at a constant elevation around the perimeter of the building.

In-Plane Rotation shown in Fig. 7(b), also known as rocking, occurs when a panel is fixed in-plane at two levels of framing. When the structure sways, lateral connections cause the top of the panel to displace laterally relative to the bottom, resulting in in-plane rotation. This rotation requires bearing connections that allow lift-off and all vertical load is transferred to one bearing connection. Panels with height much greater than width, such as column covers, can be designed this way to manage connection forces or for compatibility with other elements.

Out-of-Plane Rotation shown in Fig. 7(c) is the out-of-plane tilting of a panel. This motion is common whenever a panel is connected to the structure at different levels of framing. Tieback connections that brace the

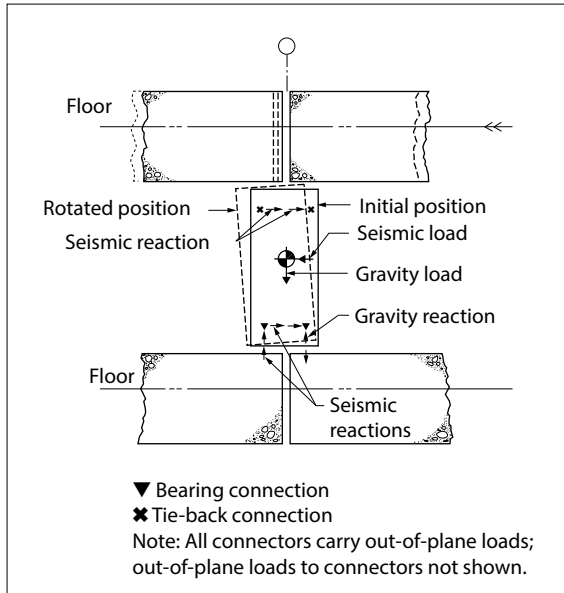

Figure 6 Rocking column cover.

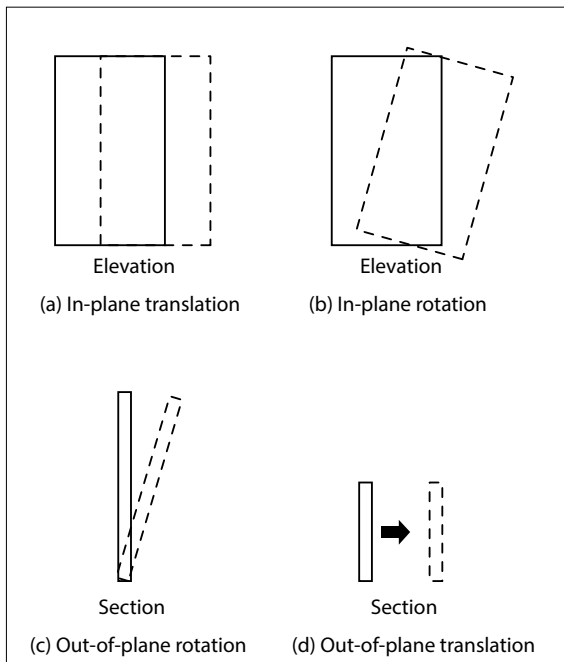

Figure 7 Modes of panel response to displacement.

panel for wind and seismic loads will also cause the panel to tilt out-of-plane during story drift. Bearing connections should be detailed to accommodate out-of-plane rotation or designed for the effect of the rotation.

Out-of-Plane Translation shown in Fig. 7(d) is common for spandrel panels attached to a single level of framing, since movement is the same as the supporting beam to which it is attached.

The first, and simplest, illustration of the concept of compatibility is to consider the panel arrangement shown in Fig. 1(a) and the connection arrangement shown in Fig. 2(d). As the structure sways due to lateral load in a direction parallel to these spandrels, each spandrel will translate in-plane an amount equal to the translation of the floor to which the spandrel is connected. However, there will be a differential translation between floors, commonly known as the story drift. Consider a horizontal band of windows now connected rigidly between the spandrels. As shown in Fig. 8, the window frame will rack as the head of the window moves with the upper spandrel and the window sill moves with the lower spandrel. For compatibility, the window detailing must either accommodate this racking or the head of the window cannot be rigidly connected to the upper spandrel.

Consider this same system but with infill column covers as illustrated in Fig. 1(b) and assume the window frames are rigidly attached top and bottom and can perform through the racking motion. The next compatibility consideration is where the windows abut the sides of the column covers. For compatibility at those joints, the column cover should rack a distance similar to the windows. This can be accomplished through the connection detailing that allows rocking. Using the connection arrangement shown in Fig. 2(a), the top and bottom tieback connections of the column cover should be rigid in the plane of the panel in the direction parallel to the length of the spandrels, but flexible vertically. This will force the top of the column cover to translate an amount similar to the top of the window. The gravity connections must be detailed to support the vertical weight of the column cover, but the detailing must allow the gravity connections to lift off the supporting element so the panel can freely rock. Depending on the amount of rocking, each gravity connection may have to be designed for the entire vertical reaction.

For that same rocking column cover arrangement, consider the joints illustrated in Fig. 6. The spandrels only translate horizontally. As the column cover rocks, the right side of the upper horizontal joint closes while the left side of the upper joint and the right side of the lower joint open. The joint size and sealant must be selected to accommodate the joint opening and the joint size must be selected to prevent contact between the top of the column cover and the bottom of the spandrel, at least for reasonable lateral load cases.

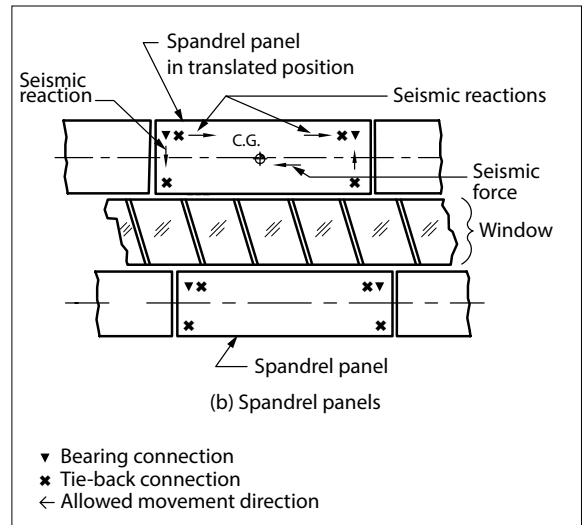

Figure 8 Story drift.

Alternatively, the column cover connections could be detailed in a different way. Instead of a rocking panel, the column cover could be detailed as a translating panel. The bottom tieback connections would be rigid both vertically and horizontally in the plane of the panel and the top tieback connections would be flexible both vertically and horizontally in the plane of the panel. Gravity connections would not be detailed to lift off. In this scenario, the top column cover joint would experience translation with shear in the sealant and the vertical joints between the sides of the column cover and the ends of the window frames would require detailing to allow extension and compression of the joint.

These simple examples illustrate the interaction of connection detailing for movement with connection design, panel movement, joint movement, sealant demands, and window performance. As panel arrangements get more complicated, these fundamental interactions must be considered to have overall compatibility of the elements of the façade.

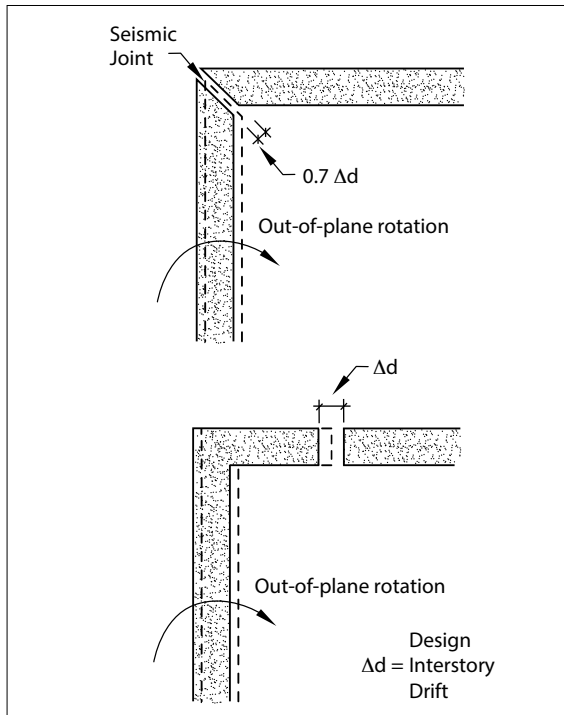

Figure 9 Corner made wider to avoid collision.,

As joint sizes are selected considering the various types of panel movement, panel contact from joint closing may dictate some joint sizes. Figure 9 illustrates corner configurations where panel contact may occur, especially if the panels are story height. The panels perpendicular to the direction of building sway will experience out-of-plane rotation while the panels parallel to the building sway will usually be detailed for in-plane translation. The joints will close at the top of the panels. For regularly occurring lateral loads causing sway, such as normal wind loads, the joint size should be selected to prevent damage from contact. For extreme events, such as an earthquake, the consequences of contact across the joint must be considered. Contact will cause panel damage, which may be acceptable in an extreme event. Contact will cause forces to be generated that may overload connections. Two options are available. The first is to select a joint size that will be large enough to preclude contact in even an extreme event. The second is to develop connection details that can either fully resist the contact forces generated or have ductility sufficient to allow inelastic deformation when contact forces are generated. The viability of the latter has been demonstrated in a recent shake table test.

The preceding discussion does not apply if the architectural precast concrete units are either used as shear walls as part of the lateral force-resisting system or if the units are load-bearing. Similar compatibility considerations will be required, but the movements to be considered will be different. Designers are referred to an extensive treatment of design methods in PCI MNL 123-88, *Design and Typical Details of Connections for Precast and Prestressed Concrete*, PCI MNL-138-08, *PCI Connections Manual for Precast and Prestressed Concrete Construction* and PCI MNL 120-10, *PCI Design Handbook*.

Tolerances and Clearances

A primary goal when installing architectural precast concrete units is to meet industry standard erection tolerances. The obvious tolerances are on surface alignment and plumbness. The more subtle tolerances are on joint uniformity, corner alignment, and alignment of features such as reveals and stone or brick joints in veneered panels. Precast erection tolerances and building structure construction tolerances are not necessarily compatible. Therefore, reasonable clearances must be detailed into the system to allow the best opportunity for success.

When establishing the clearances between a structure and the precast concrete elements, dimensional variations in the structure must be anticipated. Variations in plumbness will depend on the building height. Sufficient clearance to the structure is required to allow the exterior elements to be erected plumb for the height of the building. Overall plan dimensions of a structure will have construction tolerances. The exterior elements can accommodate these plan dimension tolerances by providing sufficient clearance from the back of the element to the face of the structure. Additionally, erection tolerance on joint sizes will permit some accommodation of plan dimension variations. More locally, slab edges will have irregularities that proper clearances can accommodate.

It is also important to anticipate geometric variations in the supporting structure and in hardware location in the design of connections. Figure 10 shows a rather typical bearing connection used with architectural precast concrete units. The clearance from back of panel to slab edge is suggested to be 2 in. (50 mm). This would account for slab edge irregularities and panel thickness tolerance for a building up to 15 or 20 stories. Taller buildings may require a larger clearance. Note also the shim space under the bearing angle provided on the panel. This space accounts for tolerance on the angle placement in the panel, story height variations, and slab surface variations. By varying the shim stack height during erection, the vertical position of the panel can be adjusted for joint and feature alignment.

Figure 10 also shows the interaction between panel embedments and field embedments. The angle cast into the slab edge is the bearing surface for the shims. Recommended tolerances for such an embedment are ± 1 in. (± 25 mm) in all directions (vertical and horizontal) from the specified location, plus a slope deviation of no more than $\pm 1/4$ in. (± 6 mm) in 12 in. (300 mm) for bearing surfaces. From a structural design standpoint for a connection such as this, the SSE will design the connection in the panels accounting for tolerance on the location of

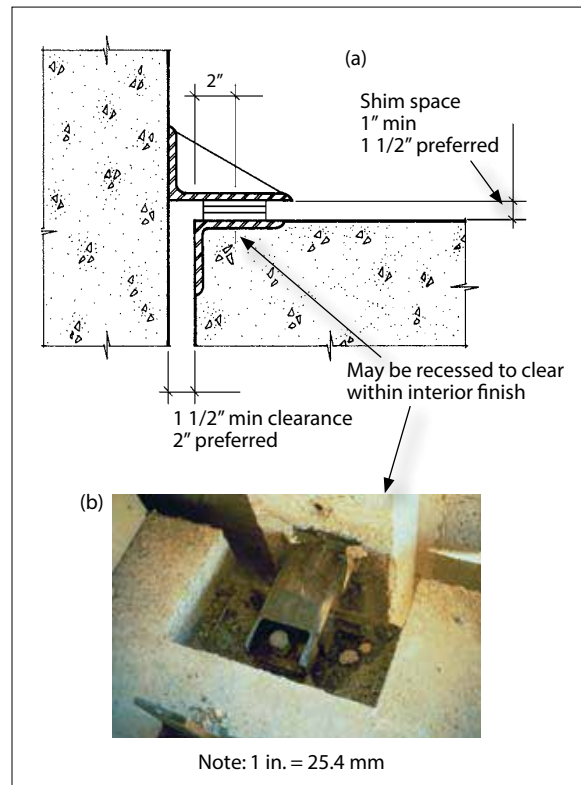

Figure 10 Dimensions for design of connections methods.,

the vertical reaction. The SER should also account for worst case tolerance on the vertical reaction location for slab design.

The detailing of interior finish systems must be coordinated to conceal the panel connection system with reasonable clearances. For example, allowing at least an extra 1/2 in. (13 mm) between back of the drywall and the theoretical inside edge of connection hardware is recommended. Top connections may be located above suspended ceilings or covered by a valance. Bearing connections at a floor level may be concealed in column furring, a full-depth slab blockout as shown in Fig. 10(b), or concealed together with mechanical services. In any of these cases, clearances must be planned to allow for tolerances.

Oversized plates, slotted inserts, or oversized holes in connection hardware can be used to accommodate plant and field tolerances. Welds, shims, and leveling bolts are used to obtain connection adjustability at the time of installation. The adjustability of connections facilitates the alignment of panels and joints.

Detailing of connections must include consideration of access to the connection. Examples are access for welding at a proper angle and clearance for a wrench to tighten a nut or bolt. When fireproofing is used, clearances should be planned from the face of the fireproofing material. For steel framing members, consideration should be given to clearances around splice plates, gussets, and projecting bolts. For braced steel frames, clearance to gusset plates is required, although detailed information on the gusset plate dimensions may only be available on steel shop drawings.

Supply of Hardware for Connections

The responsibility for supplying field hardware to be placed on or in the structure to receive precast concrete units depends on the type of structure and varies with local practice. Furnishing and placing of hardware should be clearly defined in the bid and contract documents. Hardware should be incorporated into the structure within specified PCI tolerances according to a predetermined and agreed upon schedule to avoid delays or interference with precast concrete erection and project schedule.

Building frame of structural steel. Responsibility for designing, supplying, and installing miscellaneous steel related to the precast concrete should be clearly addressed in the contract documents and discussed in a prebid meeting. This steel might include brackets off of column faces or beam sides for bearing connections, floor beams or kickers to brace edge beams with eccentric load, angle brackets hung from beams for tieback connections, and stiffeners for localized forces from connections. This steel is most efficiently provided with the steel package and installed in the fabrication shop. Field installation of such materials can cost three to five times the cost in the shop. This requires sufficient coordination time to provide proper hardware locations before detailing and fabrication of the steel. It is recommended that the SER and the SSE work together to most effectively develop information for the steel supplier.

When timing does not permit inclusion of such items in the steel package, the precast concrete supplier can supply and install the material that is directly related to connection details. However, the SSE will not be investigating the strength or stiffness of structure to which connections are being made. For example, stiffeners for local forces or stabilizing framing for beams with eccentric load will not be designed, detailed, or supplied with the precast concrete.

Building frame of cast-in-place concrete. The primary field hardware required with a cast-in-place concrete frame is embedments for connection attachments to the frame. These embedments are most efficiently designed and detailed by the SSE and supplied to the site by the precast concrete supplier. Layout drawings are provided so the embedments can be installed in the field as determined by the General Contractor (GC). Alternatively, field hardware may be supplied by the GC or be a part of the miscellaneous steel subcontract. While this method of supply may assure better coordination of schedule, it will be more cumbersome if multiple material orders are required.

If anchors or other structural items shown on the precast concrete manufacturer's approved drawings cannot be accommodated because of mislocation, unforeseen reinforcing complications, or work of other trades, the GC should obtain approval for any modifications by both the SER and SSE to ensure the required structural adequacy of the hardware.

Field-installed, pre-erection hardware consists of miscellaneous loose steel pre-welded or pre-bolted to the structure prior to beginning panel installation. It is customary for the precast concrete manufacturer to supply this erection hardware even when not performing actual erection.

Erection hardware is the loose hardware needed in the field for final connection of the precast concrete units and is normally supplied by the precast concrete supplier.

Accessory hardware includes such items as electrical boxes, conduit, window inserts, fastenings for other trades, and dovetails for flashing that is planned to be cast into the precast concrete units. Such hardware should be detailed and supplied to precast concrete supplier by the trade requiring them. The issue most difficult with accessory hardware is timely delivery of the hardware to meet the casting schedule in the precast concrete plant. Delays in delivery will either result in hardware not being installed or costly delays in production.

Connection Details

This section shows typical details for some of the more commonly used connections for cladding panels and loadbearing precast concrete walls, as well as other connections that may be useful in special applications. The details included are not exhaustive. They should not be considered as "standard," but rather, as concepts on which to build. Detailed design information, such as component sizes, weld and anchorage lengths, joint sizes, and bearing pad thicknesses is purposely omitted.

There are many possible combinations of anchors, plates, steel shapes, and bolts to form various connection assemblies. The details and final assemblies selected should be optimized considering design criteria, production and erection methods, tolerances, and economy. Common practice by precast concrete suppliers in a given area may also influence the final selection of details on a particular project.

It is not the intent to limit the type of anchorage of any connector to the precast concrete to that shown in the figures. A variety of anchors are shown, which are generally interchangeable and must be integrated with the reinforcement by the SSE for each individual project.

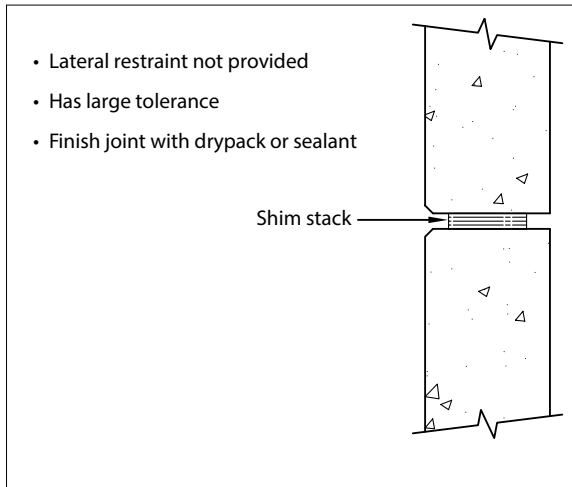

Figure 11 Direct bearing (DB1).

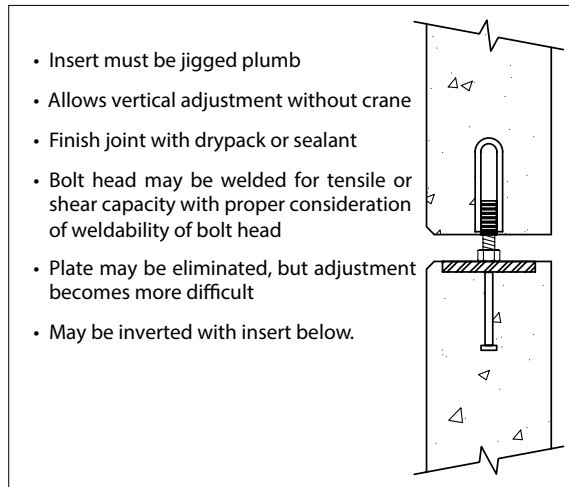

Figure 12 Direct bearing (DB2).

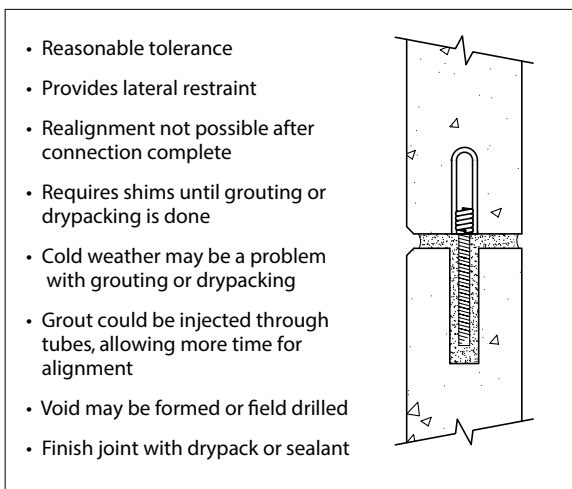

Figure 13 Direct bearing (DB3).

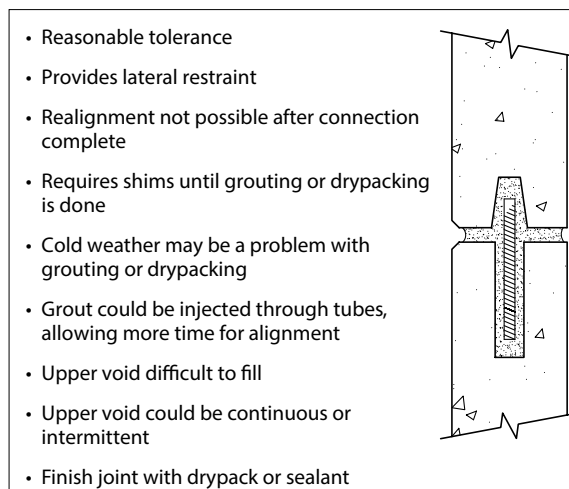

Figure 14 Direct bearing (DB4).

The connection details shown are grouped by category and a brief discussion of each category follows.

Bearing (direct and eccentric) connections (Fig. 11 to 24) are intended to transfer vertical loads to the supporting structure or foundation. Bearing can be either directly in plane of the panel along bottom edge, or eccentric using continuous or localized reinforced concrete corbels or haunches, cast-in steel shapes, or attached panel brackets. Transfer of loads perpendicular to the panel is provided by various tieback arrangements. Bearing connections are usually, but not always, combined with tiebacks. Adjustability in the support system generally necessitates use of shims, leveling bolts, bearing pads, and oversized or slotted holes.

Direct bearing connections are used primarily for panels resting on foundations or rigid supports where movements are negligible. This includes cases where panels are stacked and self supporting for vertical loads with tieback connections to the structural frame, floor, or roof to resist loads perpendicular to panel.

- Full strength of bar can be achieved with proprietary grouted sleeve
- Sleeve requires proprietary grout while drypack does not
- Small tolerance requires jiggling
- Requires shims until grouting or drypacking is done
- Joint may be drypacked or grouted at same time as sleeve
- Smooth or corrugated sleeve could replace proprietary sleeve for lower capacity
- Finish joint with drypack or sealant
- Sleeve can be in either panel

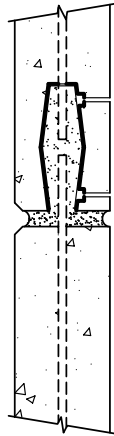

Figure 15 Direct bearing (DB5).

- For shaped panels: can eliminate dead load overturn if shims in line with panel center of gravity
- Complex forming, especially if location of haunch changes
- Forming simplified if a bolt-on steel haunch is used

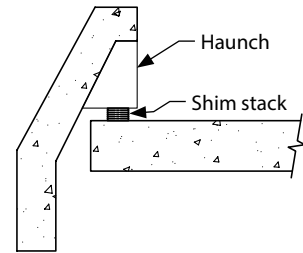

Figure 16 Direct bearing (DB6).

- Preferable if column bearing bracket shown on contract drawings and shop-installed
- Cost substantially more if bracket field-installed, which also requires field layout
- Leveling bolt could be used in lieu of shims
- Can be used in pocket farther up panel away from joint

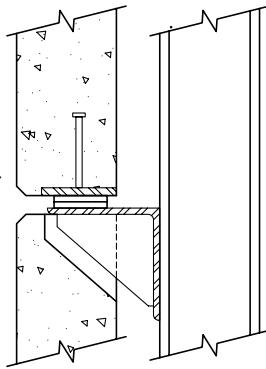

Figure 17 Direct bearing (DB7).

- Lateral restraint could be provided by welding bolt head to seat with proper consideration of weldability of bolt heads
- Could use threaded insert in lieu of angle assembly

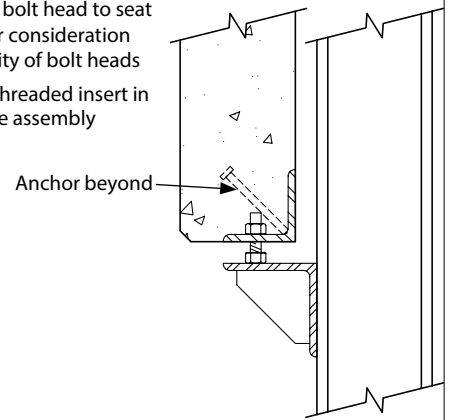

Figure 18 Direct bearing (DB8).

- Coordinate with GC for placement of seat
- Could use leveling bolt or shims
- Could use thicker angle and delete gusset
- Could eliminate projection from panel by attaching angle with inserts or welding to flush plate

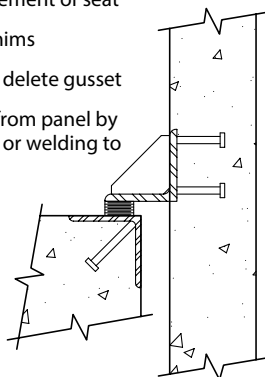

Figure 19 Eccentric bearing (EB1).

- Coordinate with GC for placement of seat
- Complex haunch reinforcement
- Complex forming, especially if location of haunch changes
- Haunch could be cast first and set in form
- Haunch could be intermittent or continuous
- Plate washer may require welding for lateral loads

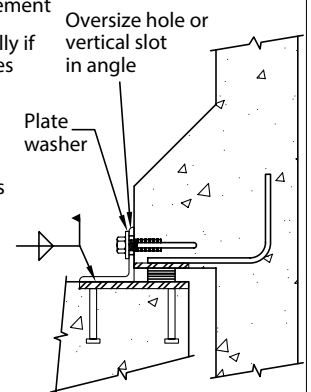

Figure 20 Eccentric bearing (EB2).

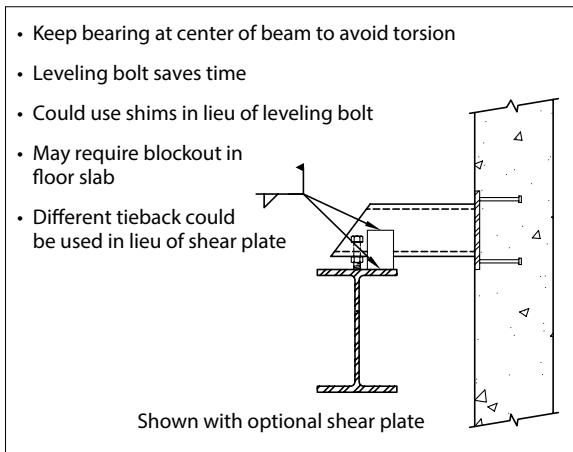

Figure 21 Eccentric bearing (EB3).

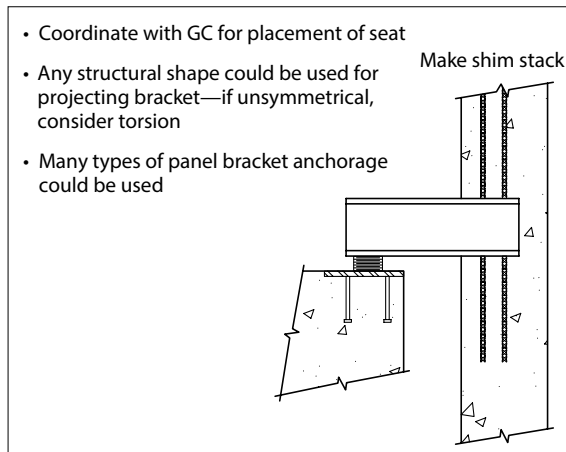

Figure 22 Eccentric bearing (EB4).

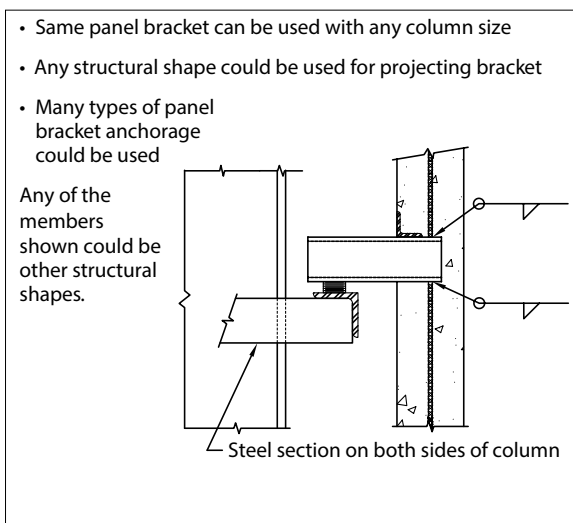

Figure 23 Eccentric bearing (EB5).

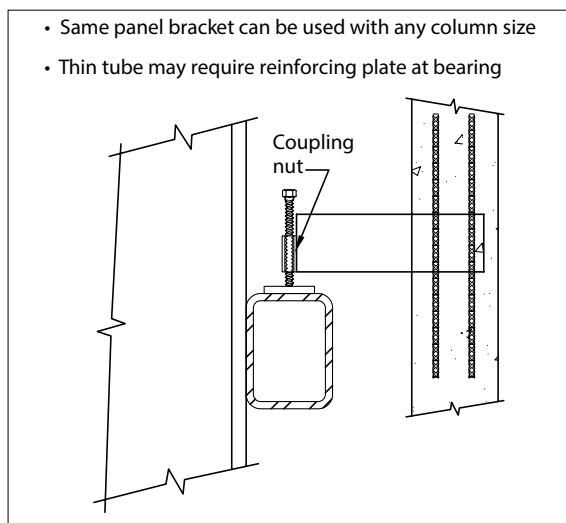

Figure 24 Eccentric bearing (EB6).

Eccentric bearing connections are usually used for cladding panels because they are located in a different plane than the supporting structure. Eccentric bearing connections cause permanent bending stresses in the supported panel that must be accommodated. Bending, combined with tension, shear, and torsion, may have to be resisted by the connection and, in turn, the structure, depending on the type of connection and load transfer details.

Tieback (welded or bolted) connections (Fig. 25 to 40) are primarily intended to keep a precast concrete unit in a plumb position and to resist out-of-plane wind and seismic loads. Welded tiebacks may require temporary bracing during alignment. Tiebacks may be designed to take forces in the plane of the panel, but a primary consideration in the detailing of tiebacks is to allow movements in directions where force resistance is not required.

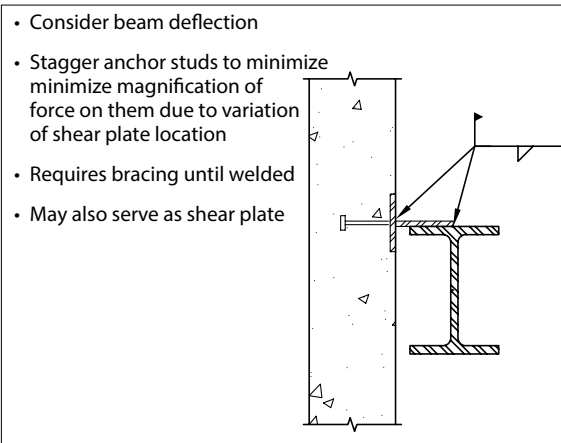

Figure 25 Welded tieback (WTB1).

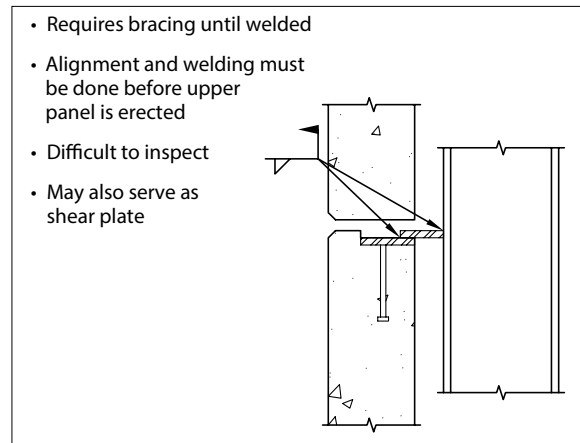

Figure 26 Welded tieback (WTB2).

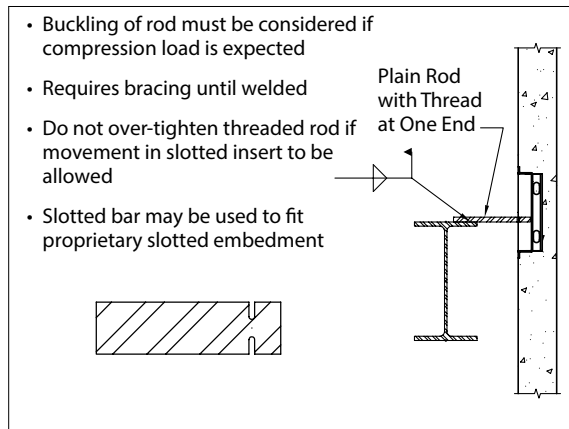

Figure 27 Welded tieback (WTB3).

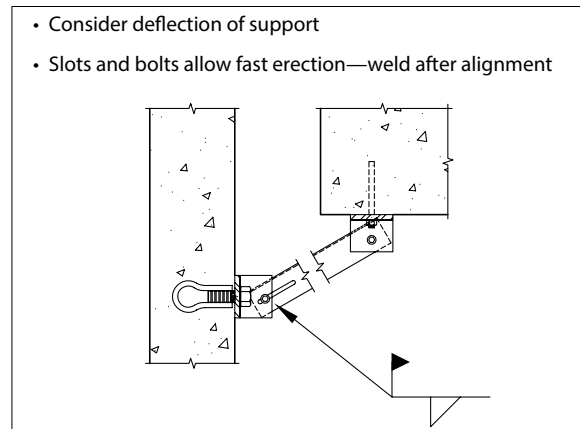

Figure 28 Welded tieback (WTB4).

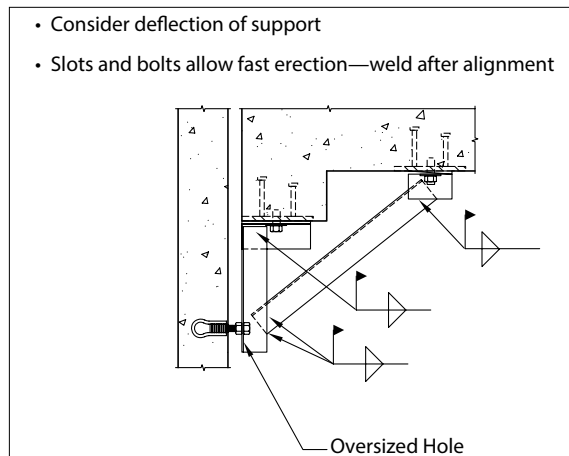

Figure 29 Welded tieback (WTB5).

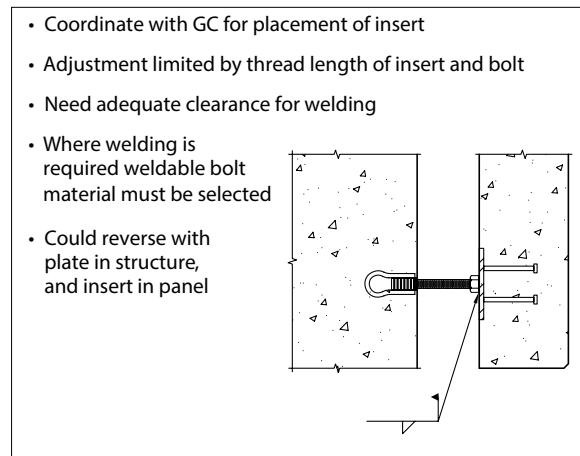

Figure 30 Welded tieback (WTB6).

- Anchorage of plate and angle could vary
- Shear plate configuration to be determined by load type

Figure 31 Welded tieback (WTB7).

- Oversize hole in angle
- Plate washer could be welded and slotted to control directional movement

Figure 32 Welded tieback (WTB8).

- High-strength rod is advantageous
- Rod flexes for in-plane movement
- Buckling of rod must be considered if compression load is expected
- Oversize hole primarily for tolerance

Figure 33 Bolted tieback (BTB1).

- Alignment can be completed after release from crane
- Slots in embedment and angle to be perpendicular to each other for three-way adjustment
- Threaded insert can be used if angle has oversized hole and plate washers

Figure 34 Bolted tieback (BTB2).

- Horseshoe shims allow adjustment perpendicular to panel
- Oversize hole and plate washer allows adjustment parallel to panel
- Do not over-tighten bolt if movement to be allowed
- Plate washer could be welded and slotted to control directional movement See Fig. 14

Figure 35 Bolted tieback (BTB3).

- Coordinate with GC for placement if insert is used
- Edge distance and reinforcing in floor/foundation must be considered
- Angle has slotted holes

Figure 36 Bolted tieback (BTB4).

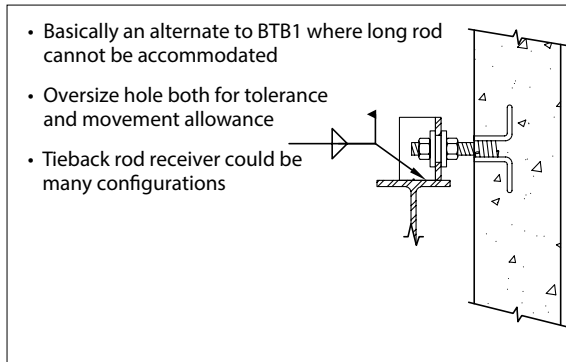

Figure 37 Bolted tieback (BTB5).

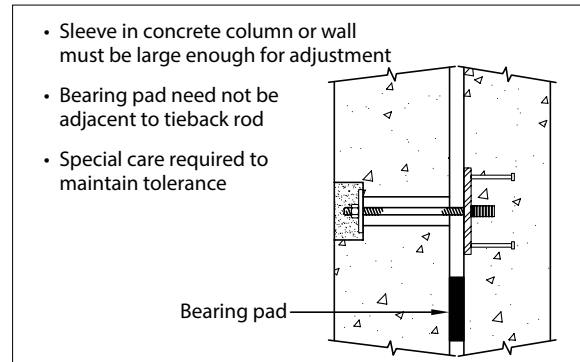

Figure 38 Bolted tieback (BTB6).

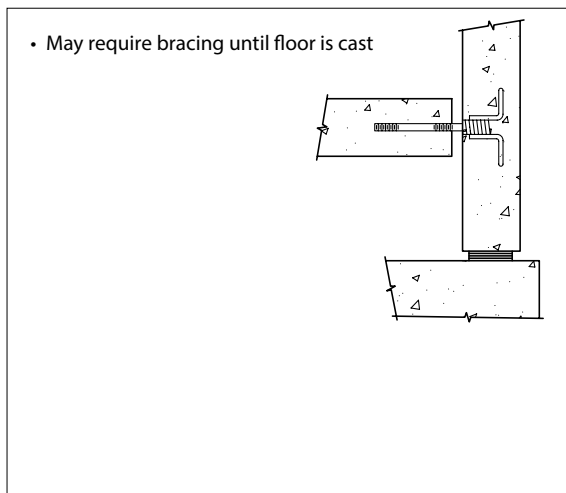

Figure 39 Bolted tieback (BTB7).

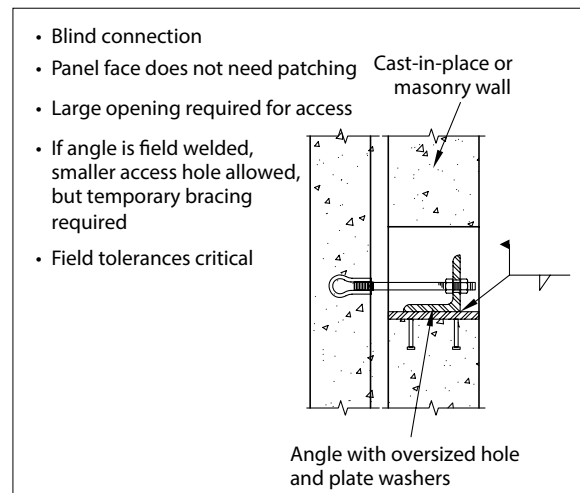

Figure 40 Bolted tieback (BTB8).

Shear plates (Fig. 41 to 47) are generally welded and serve primarily to provide restraint for longitudinal in-plane panel loads, but will also act as a tieback for out-of-plane loads. Because the most common in-plane force is due to seismic effects, these plates are sometimes referred to as seismic shear plates. To minimize volume change restraint forces on longer panels such as spandrels, shear plates may be located near mid-length of the panel. Shear plates may also be combined with long eccentric bearing connections as shown in Fig. 42 rather than attempting to resist both vertical and in-plane forces on a bearing bracket.

- Primarily for in-plane lateral force
- Also takes out-of-plane force
- Normally one used near center of panel, with larger panel to beam dimension, so force needn't be restricted by long panel brackets
- Trapezoidal plate may be assumed fixed at beam and pinned at panel to minimize panel plate anchorage
- Installed after panel fully aligned, so temporary tieback may be required
- Thin plate allows some vertical movement

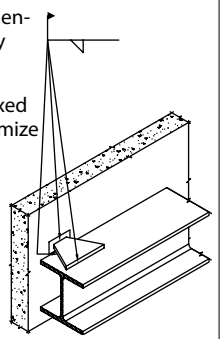

Figure 41 Shear plate (SP1).

- Similar to SP1 except combined on bearing connector anchor plate
- Eliminates need for shear plate on bearing bracket
- Panel plate anchorage requirement is lower than if in-plane force were resisted by bracket

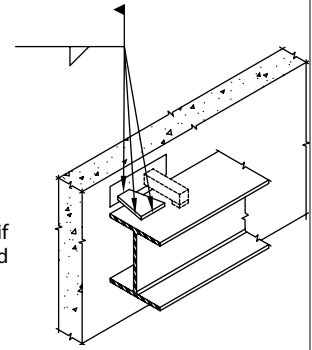

Figure 42 Shear plate (SP2).

- Convenient at mid-height of column covers
- Can be used for rocking or translating unit, depending on balance of connection system
- Use in pairs or weld to column

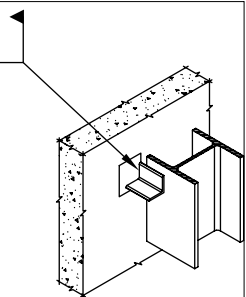

Figure 43 Shear plate (SP3).

- Shims carry full weight of panel
- Shims should be adjacent to shear plate (angle)
- Angle orientation gives high capacity in all three axes
- Cannot be installed until after alignment, so temporary tieback may be required
- If leveling bolt were recessed into sill for ease of alignment, patching might be required

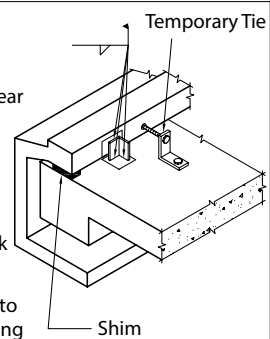

Figure 44 Shear plate (SP4).

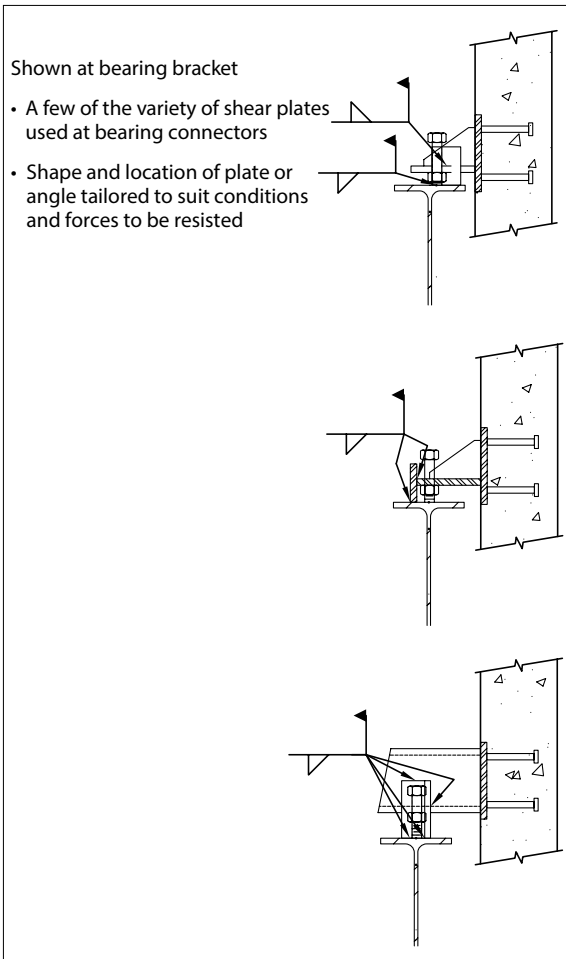

Figure 45 Shear plate (SP5).

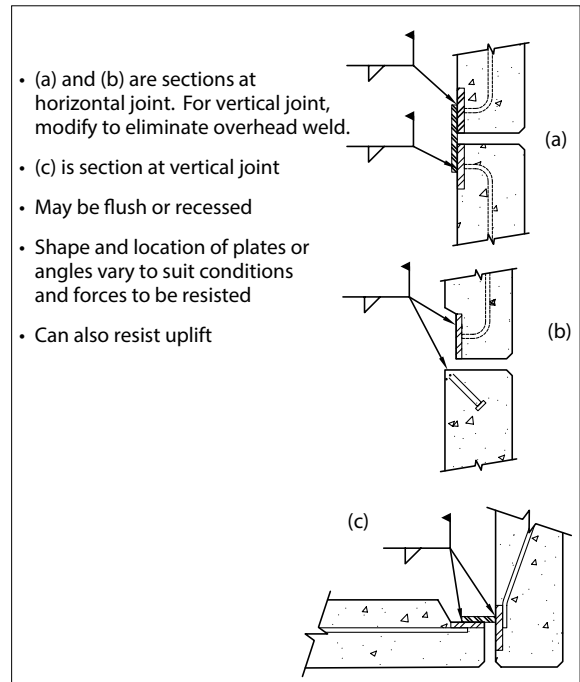

Figure 46 Shear plate (SP6).

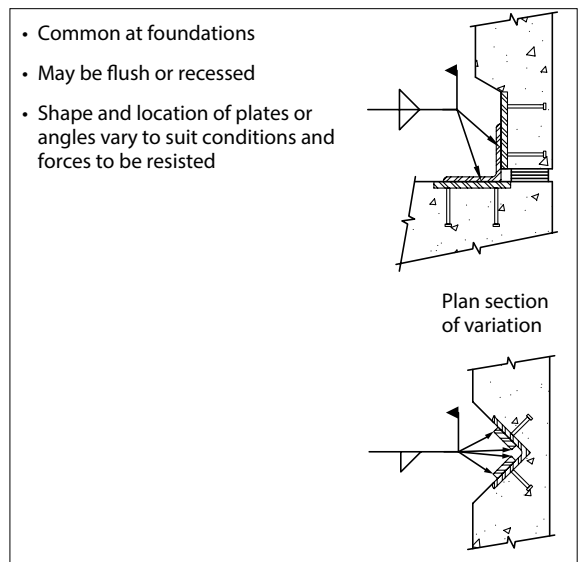

Figure 47 Shear plate (SP7).

- Not intended for required out-of-plane force resistance, but can be adapted to serve as tieback, as in Fig. 64
- Dimension to face of panel is critical
- Good solution when slightly bowed panels are not accessible after erection
- If panels are accessible after erection, finger plates can be field welded and shimmed if necessary

Figure 48 Panel to panel alignment (PPA1).

- Not intended for required out-of-plane force resistance, but can be adapted to serve as tieback
- Shim thin panel if necessary

Figure 49 Panel to panel alignment (PPA2).

- Not intended for required out-of-plane force resistance, but can be adapted to serve as tieback
- Panels must be aligned before welding
- Option (a) requires vertical weld, inside narrow joint
- Option (b) allows downhand weld, inside narrow joint

Figure 50 Panel to panel alignment (PPA3).

- Not intended for required out-of-plane force resistance
- A few of the variety of alignment connectors
- Shape and location of embeds and weldable loose slugs tailored to suit conditions

Figure 51 Panel to panel alignment (PPA4).

Panel-to-panel alignment connections (Fig. 48 to 51) are used to adjust the relative position between two adjacent units. They do not usually transfer design loads. Out-of-plane alignment of panels is sometimes necessary, especially if they are very slender and flexible.

- Serves as tieback
- Length and diameter of rod may limit capacity
- First element of column cover must be aligned prior to placing second
- Could be used for both halves if located at top
- Placement and coverage of insert is difficult in thin sections
- Shown in conjunction with Fig. 53

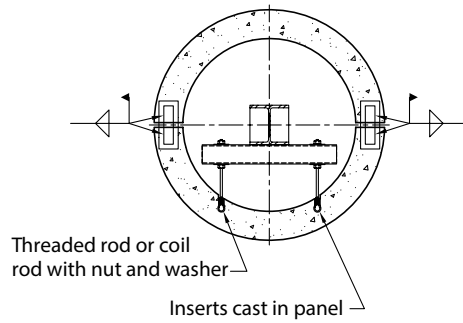
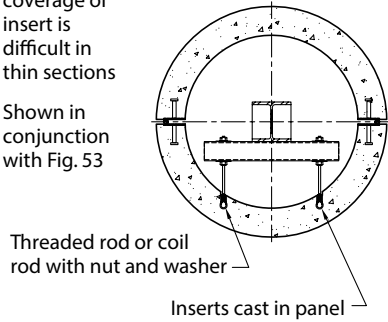

Figure 52 Column cover (CC1).

- Use where access is limited
- Exercise caution to prevent weld stain and cracking from excess heat
- Minimum recommended joint size is 3/4 in. (19mm)

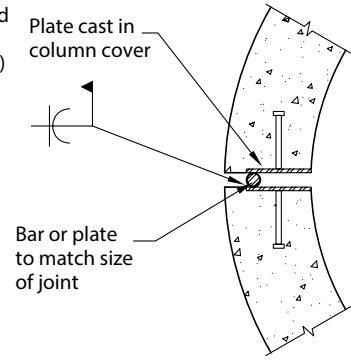

Figure 53 Column cover (CC2).

- Serves as tieback
- Used only at top for welding access
- Could be changed to bolted

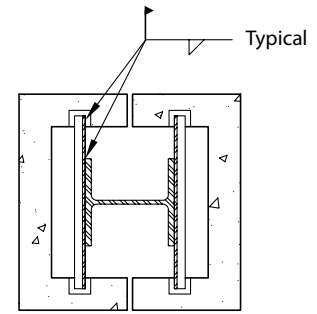

Figure 54 Column cover (CC3).

- Can be both a loadbearing and tieback connector
- Lower panel must be aligned and welded prior to placing upper portion
- Good with limited access
- Could modify to insert and bolt if ample space

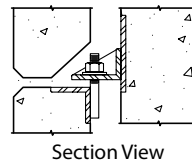
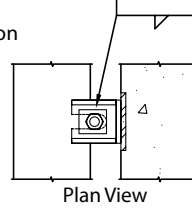

Figure 55 Column cover (CC4).

- Top connector
- Align with tieback rods prior to welding angle

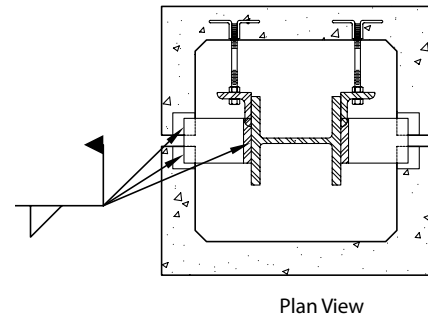

Figure 56 Column cover (CC5).

- Bottom connector
- Support unit on shims
- Joint width sets thickness of vertical plate on knife assembly
- Align and weld first unit prior to setting second
- Welding of second half difficult in narrow joint
- Allows units to rock if bent plate (or angle) legs long enough

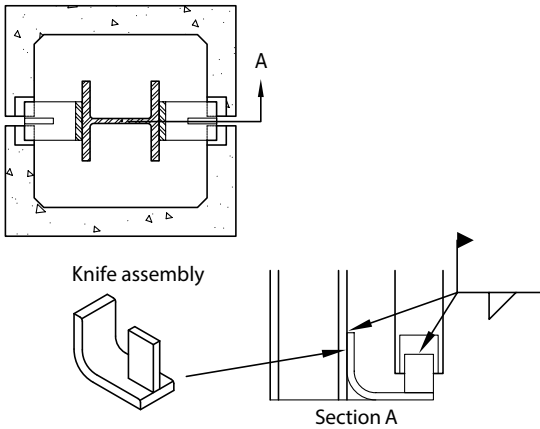

Figure 57 Column cover (CC6).

- Erection sequence critical
- Beam must be adequate to prevent excessive rotation when first element is placed
- Top right connector (alternate) requires tight tolerance
- Sealant at top left connector (alternate) is critical
- May require combination of grouting, bolting, and welding
- Preferably, use one type of alternate top connector
- Joint locations optional

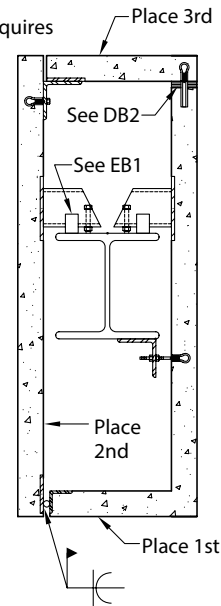
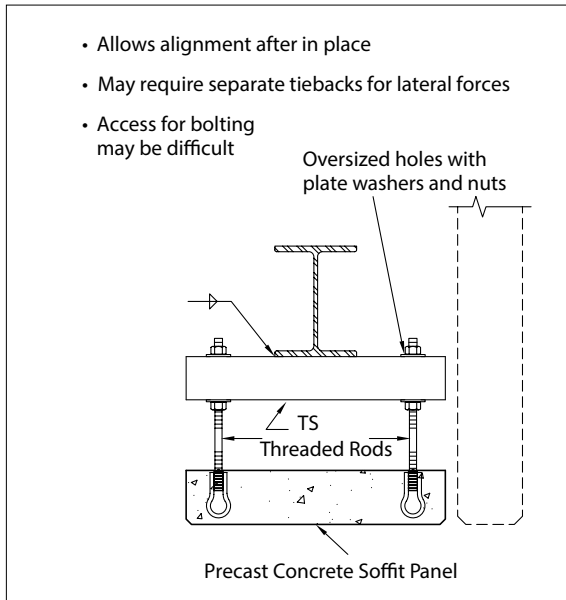

Figure 58 Beam cover (BC1).

Column and beam cover connections (Fig. 52 to 58) are used when precast concrete panels serve as covers over steel or cast-in-place concrete columns and beams. Cover units are generally supported by the structural column or beam and carry no load other than their own weight, wind, and seismic forces. The weight of a column cover section is normally supported at one level. Tieback connections for lateral load transfer and stability occur at multiple levels. Connections must have sufficient adjustability to compensate for tolerances of the structural system. Column cover connections are often difficult to reach, and once made, difficult to adjust. For thin flat units, when access is available, consideration should be given to providing an intermediate connection for lateral support and restraint of bowing. "Blind" connections, made by welding into joints between precast concrete elements, are sometimes necessary to complete final enclosure.



Soffit hanger connections (Fig. 59) can be made by modifying many of the tieback connections previously discussed. If long, flexible hanger elements are used, a lateral brace may be provided for horizontal stability.

Special conditions (Fig. 60 to 65) are suggested to help solve unique or difficult situations.

Figure 59 Soffit hanger (SH1).

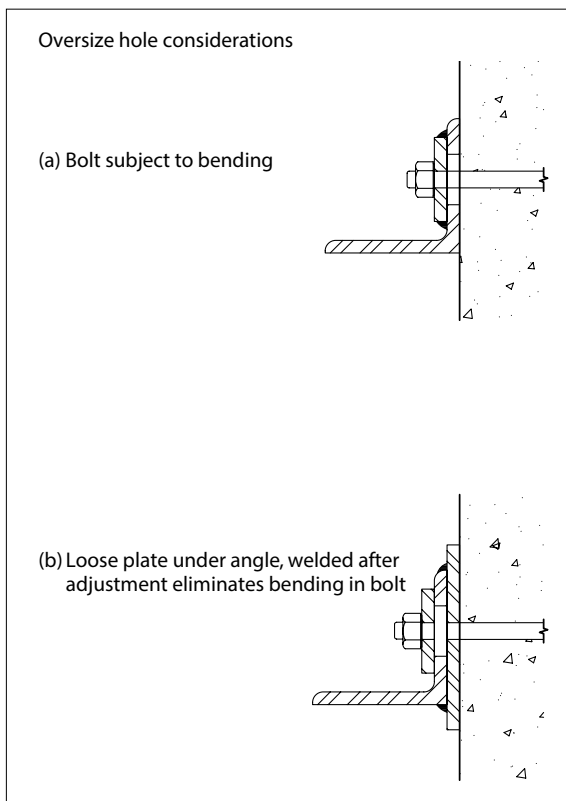

Figure 60 Special conditions (SC1).

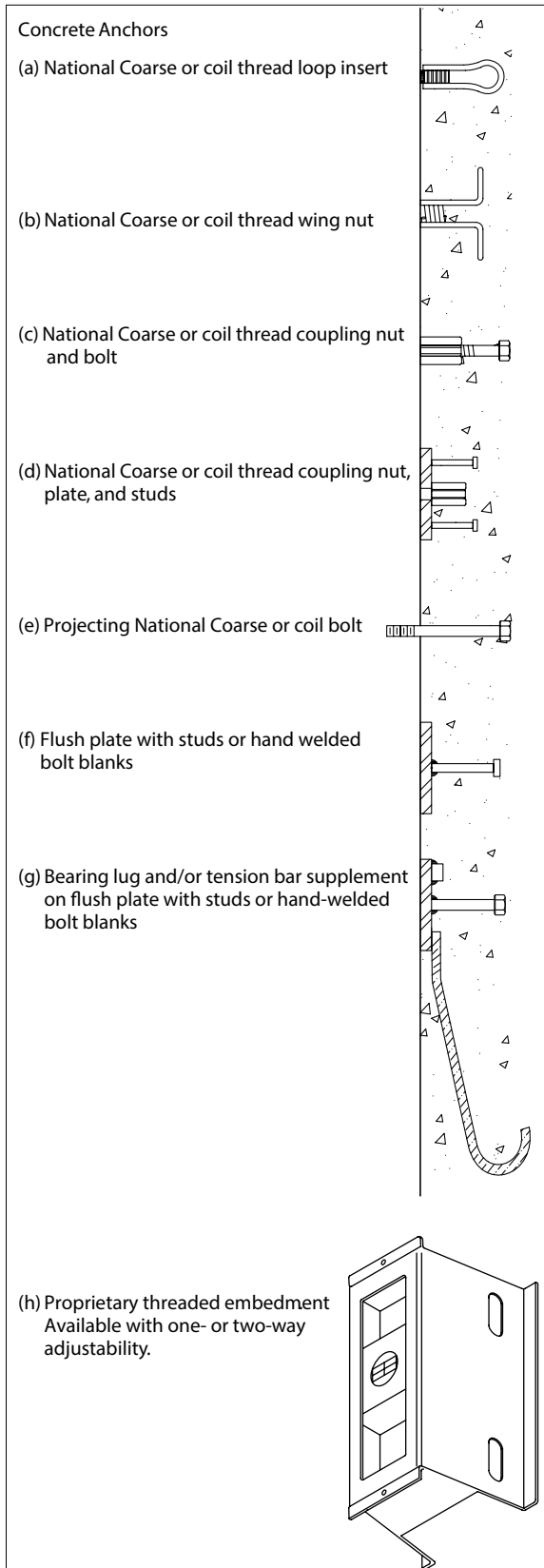

Figure 61 Special conditions (SC2).

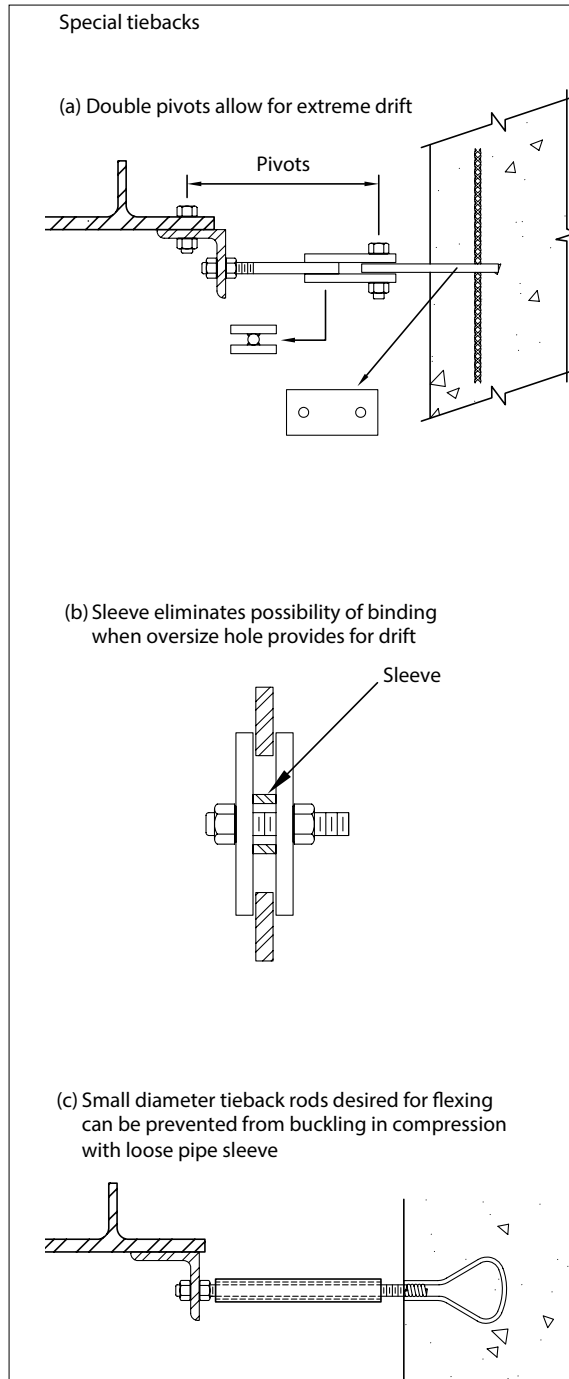

Figure 62 Special conditions (SC3).

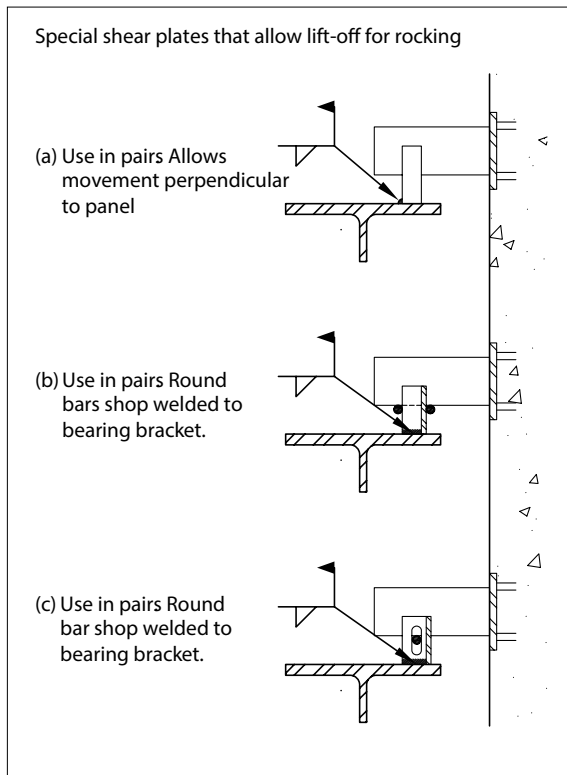

Figure 63 Special conditions (SC4).

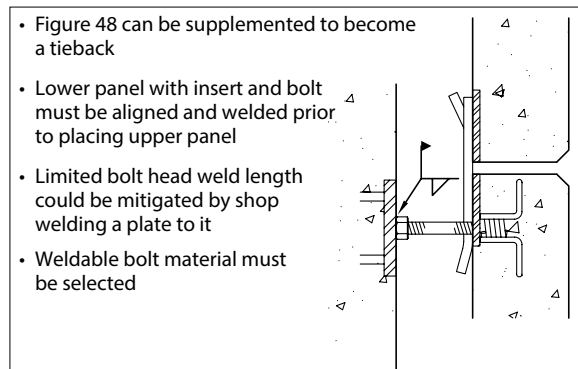

Figure 64 Special conditions (SC5).

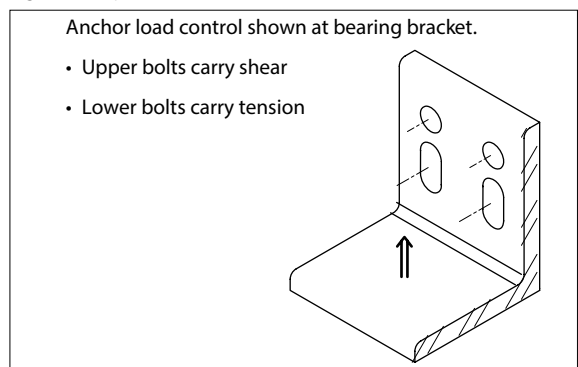

Figure 65 Special conditions (SC6).

Bearing wall to foundation connections (Fig. 66 to 70) and the direct bearing connections in Fig. 11 to 15 are primarily intended to transfer gravity loads to a panel below or to the foundation, although they usually must also resist lateral loads. The connections should provide a means of leveling and aligning a panel and be capable of accepting base shear in any direction.

Slab to bearing wall connections (Fig. 71 to 73) must transmit gravity loads from precast or cast-in-place concrete floor or roof members to precast concrete bearing walls and laterally brace the bearing walls to the deck. If the bearing walls also act as shear walls, diaphragm forces will also have to be transferred.

Corbels or ledges may be used to transfer vertical gravity loads. Blockouts in wall panels or spandrels as in Fig. 71(e), 71(f), and 72 decrease eccentricity, reducing bending in wall panels or torsion in spandrels. In the case of a fine textured finish, there may be a light appearing area (the approximate size of the blockout) that shows on face of panel due to differential drying. This may be quite noticeable, despite the uniformity of the finish.

- Can be designed for shear and uplift
- Could develop moment resistance by placing a connection on each side of wall
- Shim prior to drypack

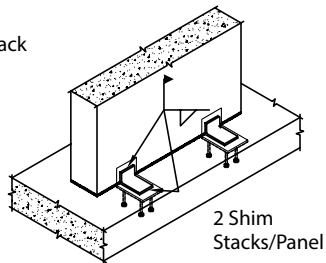

Variations

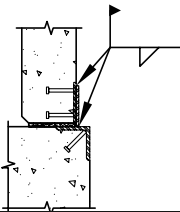
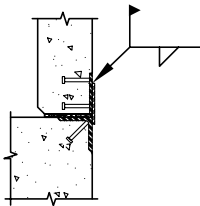

Figure 66 Bearing wall to foundation (BWF1).

- Can be designed for shear, uplift, and nominal moment capacity
- Requires bracing until welded

Concrete Slab on Grade

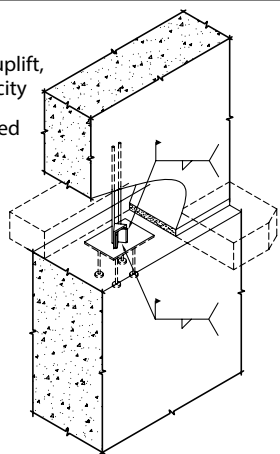

Figure 69 Bearing wall to foundation (BWF4).

- Insert must be jigged plumb
- Allows vertical adjustment without crane
- Finish joint with drypack or sealant
- Bolt head may be welded for tensile or shear capacity with proper consideration of weldability of bolt head
- Plate may be eliminated, but adjustment becomes more difficult
- May be inverted with insert below

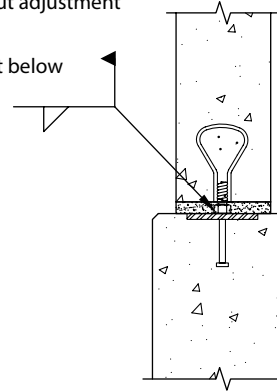

Figure 67 Bearing wall to foundation (BWF2).

- Has shear, uplift, and moment capacity
- Plate may be eliminated, but adjustment
- Location and alignment of dowels critical
- Capacity can be increased with confinement reinforcing
- Dowels projecting from panel create storing and shipping problems
- Requires bracing until grouted
- Grouting could be done after alignment if injection tube used
- Could be inverted with sleeve and injection tube in panel

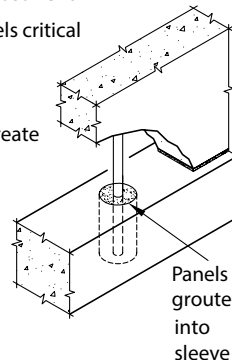
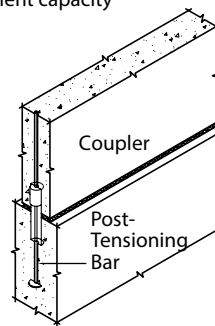

Figure 68 Bearing wall to foundation (BWF3).

- Bar could be prestressed or mild steel
- Substantial shear, uplift, and moment capacity
- Tolerance for placement of bars and sleeves critical
- May require grout tubes and vents
- Preferably grout from bottom to eliminate voids
- Bracing required until drypacked and grouted
- Void in foundation at bar essential for field alignment
- Foundation void can be formed with EPS (expanded polystyrene) or foam pipe insulation



2 Shim Stacks/Panel

Figure 70 Bearing wall to foundation (BWF5).

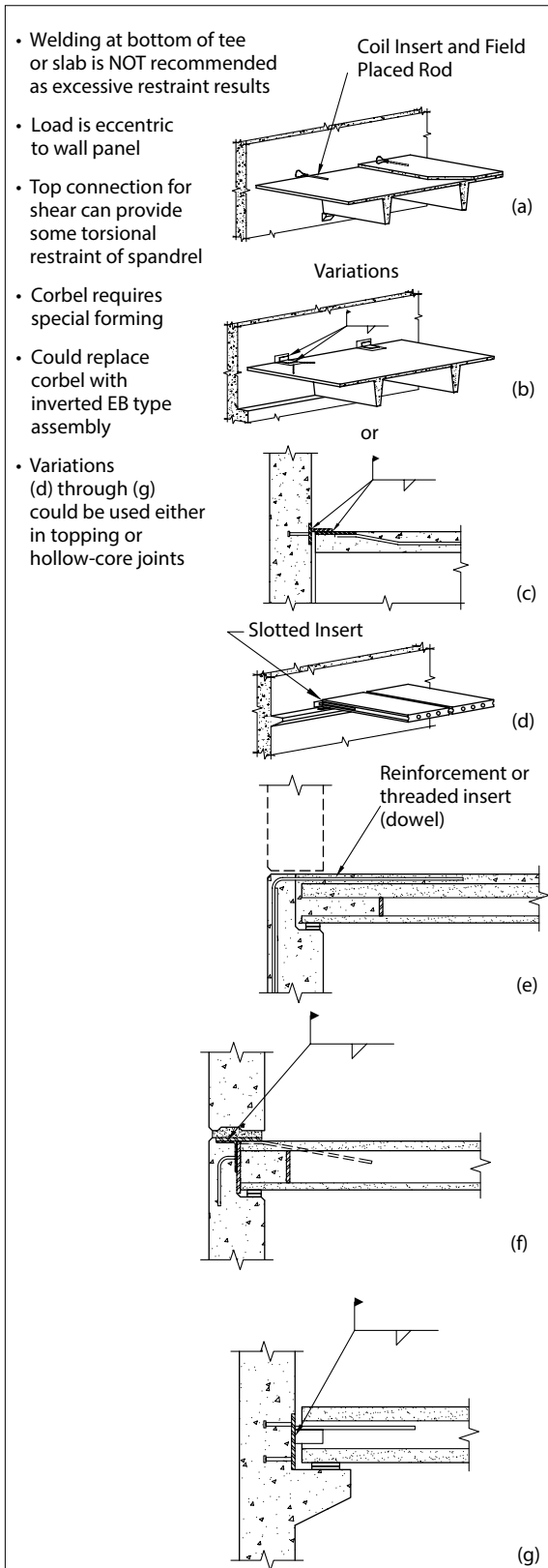

Figure 71 Slab to bearing wall (SBW1).

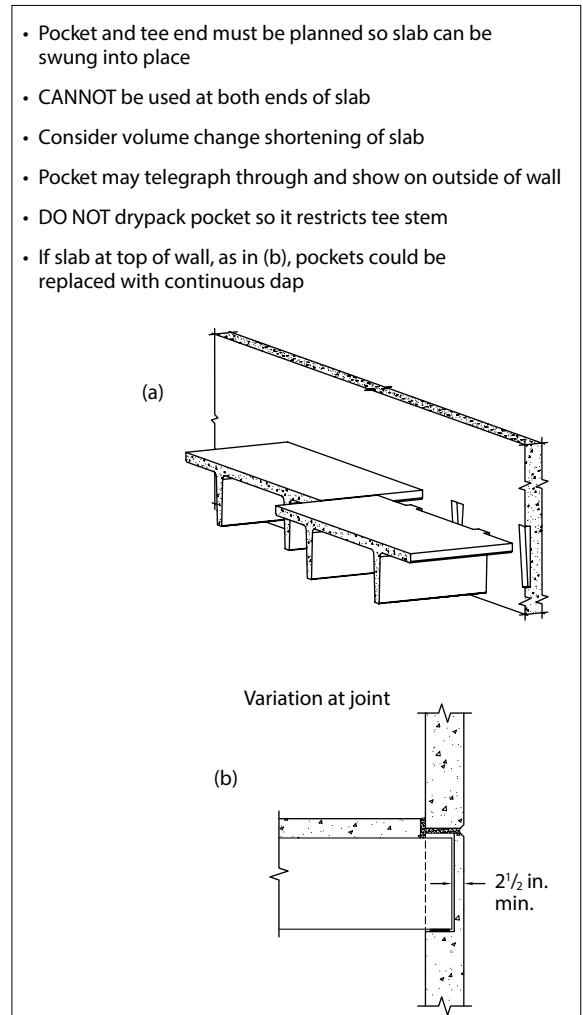

Figure 72 Slab to bearing wall (SBW2).

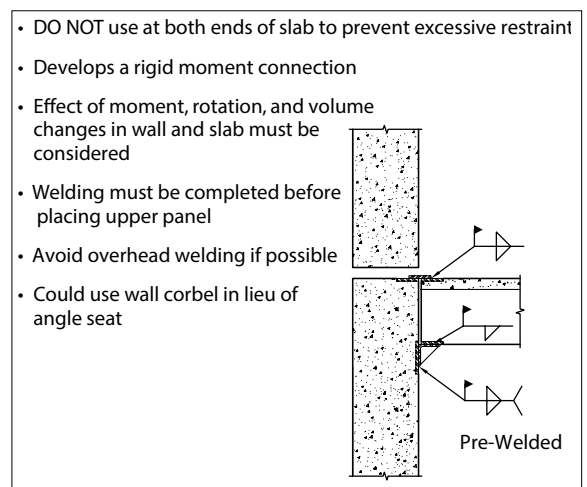

Figure 73 Slab to bearing wall (SBW3).

Slab-to-side wall connections (Fig. 74) along the non-bearing sides of floor or roof slabs must laterally brace the walls to the deck and may be required to transmit diaphragm forces. The connections should either allow some vertical movement to accommodate camber and deflection changes in the floor components, or be designed to resist forces induced by restraining the vertical movement.

Wall-to-wall connections (Fig 75) are primarily intended to position and secure the walls, although with proper design and construction, they are capable of carrying lateral loads from shear walls or frame action as well. Two locations of wall-to-wall connections are horizontal joints (usually in combination with floor construction) and vertical joints. The most practical connection is one that allows realistic tolerances and ensures immediate transfer of load between panels.

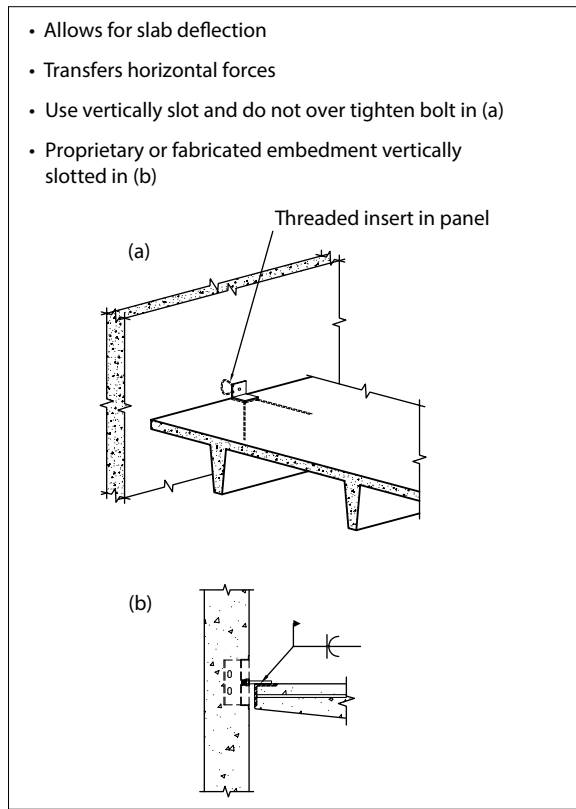

Figure 74 Slab to side wall (SSW1).

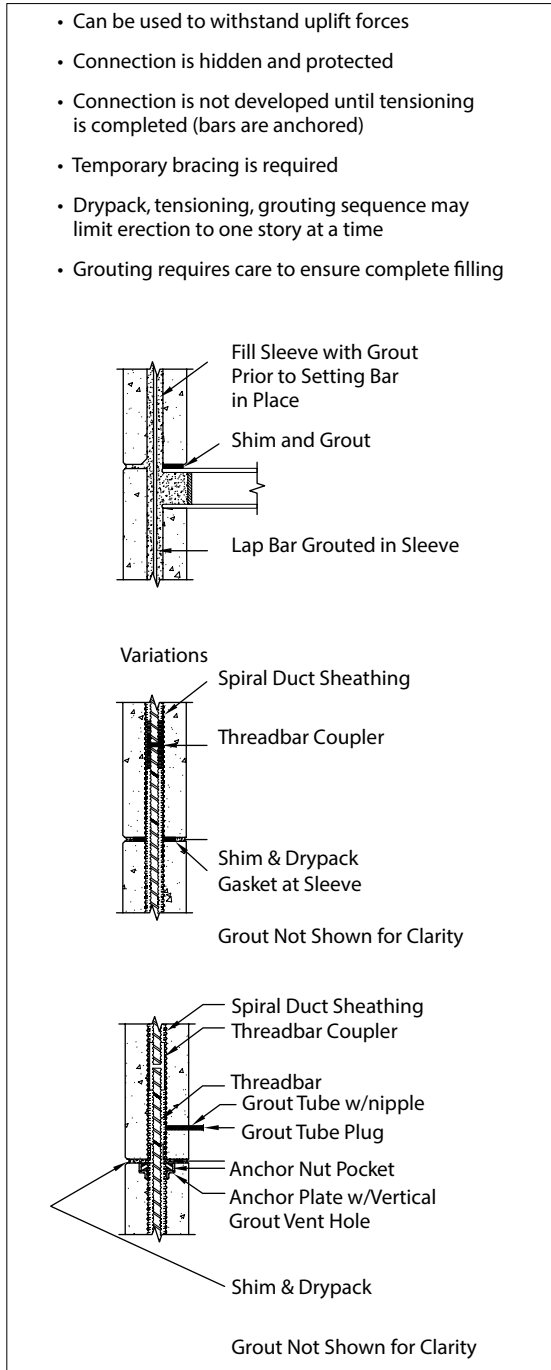

Figure 75 Wall to wall (WW1).

About AIA Learning Units

Please visit www.pci.org/elearning to read the complete article, as well as to take the test to qualify for 1.0 HSW Learning Unit.

The Precast/Prestressed Concrete Institute (PCI) is a Registered Provider with both the American Institute of Architects (AIA) and the National Council of Examiners for Engineers and Surveyors (NCEES). Continuing education credit is reported to both agencies.

All certificates of completion, for architects and for engineers, will be available from the Registered Continuing Education Provider (RCEP) web site at www.rcep.net. PCI reports data twice per month so you should see your credits appear (and your certificate will be ready) within 30 days of our receiving your completed quiz.

If you are new to the Registered Continuing Education Provider system, www.rcep.net will email you a welcome email when PCI uploads your data. That email will contain your account password. Your login name at www.rcep.net will be your email address, so you must include it when submitting your completed quiz.

Instructions

Review the learning objectives below.

Read the AIA Learning Units article. Note: The complete article is available at www.pci.org/elearning

Complete the online test. You will need to answer at least 80% of the questions correctly to receive the 1.0 HSW Learning Units associated with this educational program.

Learning Objectives:

This article provides an overview of the design concepts for connections of architectural precast concrete enclosure systems. This includes the types of connections and hardware as well as design considerations, such as fireproofing. The article also addresses who is typically responsible to supply field hardware.

1. Describe the various connection hardware and materials used for precast concrete enclosures.
2. Explain the considerations necessary to design connections properly.
3. Explain who has responsibility for supply of field hardware to be placed on or in a structure.
4. Define the different categories of connections.

Questions: contact Education Dept. - Alex Morales, (312) 786-0300 Email amorales@pci.org

QUESTIONS

1. Panel arrangement and locations of joints combined with the directions that the connection system allows movement will influence.
 - a. Size of joints
 - b. Selection of sealant materials
 - c. Interfacing with other façade elements
 - d. All of the above

2. Final design and detailing of connections of the units to the structural are performed by Structural Engineer of Record (SER).
 - a. True
 - b. False

3. The SER has the responsibility to design the supporting and bracing structure to resist the connection forces generated in the precast concrete system.
 - a. True
 - b. False

4. Panels connection generally consist of four bearing connections and a minimum of four tieback connections.
 - a. True
 - b. False

5. Welding that must be executed prior to the release of the unit from hoisting equipment should be maximized.
 - a. True
 - b. False

6. Connection hardware generally needs protection if exposed to weather or a corrosive environment.
 - a. True
 - b. False

7. Connections that can be weakened by fire, and thereby jeopardize the structure's stability should be protected to the same degree as required for the member being erected.
 - a. True
 - b. False

8. Connections must satisfy the following design criteria.
 - a. Strength
 - b. Ductility
 - c. Volume change accommodation
 - d. Durability
 - e. Constructability and economy
 - f. b and c
 - g. All of the above

9. The preferred clearance from the back of panel to slab edge is:
 - a. 1 inch
 - b. ½ inch
 - c. 2 inches
 - d. 2 ½ inches

10. The responsibility for supplying field hardware to be placed on or in the structure to receive precast concrete units depends on the type of structure and varies with local practice.
 - a. True
 - b. False

Notes

Notes